

Keep this book! You may need it for your retest.



Revised 1/2018

# Certification Training Manual

Approved by the U.S. EPA for technician training requirements under Section 609 of the Clean Air Act.

## INCLUDING:

- **CFG-12, HFG-134a and HFO-1234yf\* Refrigerant Recycling and Service Procedures for Mobile Air Conditioning Technicians**

*\* This MACS Technician Training Program conforms to and complies with the SAE International Standard J2845 "HFO-1234yf Technician Training for Service and Containment of Refrigerants Used in Mobile A/C Systems"*

- **Best Service Practices**

*The goal of this program is to provide information to technicians about safely handling automotive refrigerants.*

This program is not intended to gauge the technical skills of technicians regarding the diagnosis and repair of motor vehicle air conditioners. The basic goal of the technician training and certification program is to teach technicians how to properly recover and recycle refrigerant, and why it must be done to protect the environment.

SEE INSTRUCTIONS FOR TAKING TEST AND OTHER INFORMATION ON INSIDE FRONT COVER.



# CERTIFICATION TRAINING MANUAL

## Important Notes!

- ◆ Do not mix up tests or exchange tests with other individuals at your place of business. All tests are coded with names matching assigned numbers.
- ◆ Please review your test upon completion. Any questions marked with more than one answer will be scored as incorrect. Any question not marked will be scored as incorrect.
- ◆ Completely fill in the block ( ■ ) to the left of the correct answer.
- ◆ Do NOT mark with a check (✓) or an "x" (X).

## General Information and Instructions

You have registered for MACS certification in **REFRIGERANT RECYCLING & SERVICE PROCEDURES FOR MOBILE AIR CONDITIONING TECHNICIANS**. Following are the steps\* necessary for you to complete the prescribed training:

\* The following instructions apply to technicians taking the MACS training course by mail or online. Those participating in a classroom program should follow the instructions of their trainer/proctor. Tests given in a classroom setting must be closed-book tests. The required score for passing closed-book tests is lower than that required for passing the open-book test.

1. **Read the instruction manual that came with your recovery/recycling service equipment (and review the training video, if provided). Then read this manual cover to cover.** Re-read as necessary to gain full comprehension of the material presented.
2. **Take the test.** The test is an untimed, "open-book" test, so you may refer to the training manual as often as necessary to research answers to the questions posed. (Note, however, that you must correctly answer a minimum of 21 of the 25 questions to earn certification.) **You must complete the test by yourself, without assistance from anyone, and submit it for scoring. (See 4 below.)**
3. **Complete and sign** the "Identification and Statement of Testing Conditions" block on your test.  
**Note: A reprint charge will be incurred if information provided is not legible.**
4. **Mail your test** in the self-addressed envelope provided to: **MACS-EF, P.O. Box 88, Lansdale, PA 19446, or submit online.**
5. **MACS-EF will advise MACS of your test results.**
6. **MACS will advise you of your score and, providing that you have attained a passing score, will issue a certificate and a wallet-sized I.D. card, indicating that you have successfully completed this MACS certification training program.**
7. **Persons not attaining a passing score on the first test will receive one retest at no additional charge. If the test was originally ordered via phone, fax or mail, the second test will be sent via U.S. mail. If the original test was ordered online, the second test will also be online. If a passing score is not attained on the second test, the process begins again with a new test purchase.**

## Enclosed:

- Test with identification information to be mailed to scoring facility.
- Self-addressed return envelope (MACS-EF).

**Important - Please note: Tests must be returned for scoring within 90 days of the date they are issued. MACS assumes no responsibility for tests submitted for scoring after this 90-day period. MACS will charge an additional fee for re-issuing tests which are lost, misplaced or destroyed.**

**Note: The MACS Worldwide office is open from 8:30 a.m. until 5:00 p.m. Eastern Time.**



This publication is protected under the copyright laws of the United States and all other applicable international laws and treaties. All rights are reserved, including resale rights. No part of this publication may be reproduced or transmitted in any form, by any means (electronic, photocopying, recording, or otherwise) without the prior written permission of Mobile Air Conditioning Society Worldwide (MACS Worldwide).

Unauthorized use, reproduction or distribution of this publication, or any portion of it, may result in severe civil and criminal penalties, and will be prosecuted to the maximum extent possible under the law. If you received this publication from anyone other than MACS Worldwide, then you have received a pirated copy. We would appreciate it if you would notify us of the situation.

The information contained in this publication is based on technical data and tests, and is intended for use by persons with technical skill at their own discretion and risk. While the author(s) and publisher have made every reasonable effort to insure the accuracy of the information in this publication, they assume no responsibility for errors or omissions. Please remember that your particular situation may differ from any examples illustrated here, and so you should adjust your use of the information and any recommendations in this publication accordingly.

MACS Worldwide makes no representations or warranties concerning the information contained herein or the applications described or referred to in this publication. MACS Worldwide specifically disclaims any implied warranties, including the warranties of merchantability or fitness for any particular purpose. MACS Worldwide shall in no event be liable for any loss of profit, business interruption or any other commercial damage, including without limitation, special, incidental, consequential, or other damages arising out of the use or inability to use the presentations or applications described or referred to herein.

The identification of any product, technique, firm or business entity in this publication does not constitute an endorsement by MACS Worldwide. Any company names, products, product names, emblems, logos, images, trademarks, service marks or trade dress appearing in this publication are the property of their respective owners and are used solely in an editorial fashion. All such items are protected under federal laws of the United States and international agreements; unauthorized use is prohibited.

If you wish to contact MACS Worldwide about this publication, please refer to the information listed below.



## **MACS WORLDWIDE**

P.O. Box 88

225 S. Broad Street

Lansdale, Pa, 19446

Voice: 215-631-7020 • Fax: 215-631-7017

E-mail: [info@macsw.org](mailto:info@macsw.org) • Website: [www.macsw.org](http://www.macsw.org)

MACS and the MACS logo are registered trademarks of the Mobile Air Conditioning Society Worldwide.

All Rights Reserved. Printed in the U.S.A.

© 1990, 2008, 2011, 2013, 2014, 2015, 2016, 2018 Mobile Air Conditioning Society Worldwide



## FOREWORD

World vehicle manufacturers are currently required to meet international regulatory requirements to use lower global warming potential (GWP) refrigerants in new vehicle A/C systems. This MACS Technician Training Program conforms to and complies with the SAE International standard J2845, “*HFO-1234yf Technician Training for Service and Containment of Refrigerants Used in Mobile A/C Systems.*”

Some of the practices, techniques, procedures, tools, information and equipment required to service HFO-1234yf and other alternative refrigerant systems are different from those commonly used on CFC-12 and HFC-134a systems. No technician should perform service or repair on a mobile air conditioning system without being trained to handle the refrigerant the system contains.

While SAE standards are voluntary and developed through industry consensus, historically the U.S. Environmental Protection Agency has incorporated SAE standards into federal regulations by reference. Additionally, some individual states require compliance with SAE standards, particularly those related to safety. For example, many states refer to SAE J639, “*Safety Standards for Motor Vehicle Refrigerant Vapor Compression Systems*” in various laws and regulations.

MACS Worldwide acknowledges and thanks the U.S. EPA, SAE International, and the industry’s many manufacturers and suppliers who allowed their data and products to appear in this manual.

### **Standard J639: Safety Standards for Motor Vehicle Refrigerant Vapor Compression Systems**

*Issuing Committee: SAE International Interior Climate Control Steering Committee*

- This SAE Standard applies to refrigerant vapor compression systems that provide cooling and/or heating for passenger cars, light trucks and commercial vehicles (on and off road) that use automotive type mobile air conditioning (MAC) systems. Large trucks, buses and other vehicles that do not use typical automotive A/C systems or use refrigerants not listed in this document are not covered by this standard. This standard covers any vehicle with a MAC system using a belt or electric motor driven compressor.
- This document provides standards for design, assembly, test and service of MAC systems to minimize environmental, health and safety impacts. Also included are cautionary statements for the service industry to alert technicians to the inadvisability and possible health or safety effects associated with venting refrigerant during service. This document addresses only HFC-134a (R-134a), carbon dioxide (R-744), and HFO-1234yf (R-1234yf) refrigerants.
- To prevent system contamination, all refrigerants used in mobile air conditioning vapor compression systems require unique service fittings and service equipment. The unique service fittings are intended to eliminate the potential for system refrigerant cross-contamination during service activity. CFC-12 (R-12) is no longer in use in new MAC systems. The service fitting description is maintained as a reference for older vehicles still in use. When retrofitting an R-12 system to use R-134a or when removing R-12 (vehicle disposal), use service equipment designed for R-12 and certified to meet the requirements of SAE J1990 (R-12 recovery and recycle equipment).
- HFC-152a is an A2 flammable refrigerant as classified by ASHRAE 34 and should be used only with a secondary loop application. However, until MAC systems are developed to use HFC-152a (R-152a), no SAE Standards for system design, service equipment or service procedures have been established. The R-152a service fittings described within this Standard were established as part of the industry’s evaluation of replacement refrigerants and are maintained for future design guidance and to prevent potential refrigerant cross contamination.



# TABLE OF CONTENTS

**The Switch to Climate-Friendly Refrigerants . . . . . 1**

    Introduction . . . . . 1

    Servicing of Future Mobile Air Conditioning Systems . . . . . 2

    Federal Regulations Affecting Mobile A/C System Service . . . . . 5

    Service Procedures for Mobile Air Conditioning Systems . . . . . 11

    Refrigerant Recovery and Recycling Procedures . . . . . 13

**Best Service Practices for Mobile A/C Systems . . . . . 17**

    Sources of Refrigerant Emissions. . . . . 17

    Incorrect System Charges – Some Reasons Why . . . . . 25

    Avoiding Refrigerant Contamination . . . . . 29

**Best Service Practices for HFO-1234yf Systems. . . . . 42**

    Introduction . . . . . 42

    HFO-1234yf: Specific Safety Procedures . . . . . 43

    Unique Properties of HFO-1234yf Systems . . . . . 44

    Tanks, Labels, and Fittings. . . . . 46

    Identifying HFO-1234yf . . . . . 47

    Finding Leaks . . . . . 48

    Using Recovery, Recycling, and Recharging Equipment . . . . . 50

    System Servicing Procedures. . . . . 52

    EPA SNAP Rules . . . . . 52

**Refrigerant Recycling and Service Procedures  
for Mobile Air Conditioning Technicians. . . . . 53**

    The Historical Context . . . . . 53

    Ozone Depletion. . . . . 53

**Equipment Certification Form . . . . . 57**

**EPA Regional Offices. . . . . 58**

**Air Conditioning & Heating Customer Questionnaire . . . . . 59**

**A/C/ Heating/ Ventilation/ Cooling System Checklist . . . . . 60**







# THE SWITCH TO CLIMATE-FRIENDLY REFRIGERANTS

## INTRODUCTION

Before the early 1990s, mobile air conditioning systems used CFC-12 refrigerant, a substance that destroys the stratospheric ozone layer that shields the earth from the sun's harmful ultraviolet radiation.

Automobile manufacturers replaced CFC-12 with HFC-134a in the mid-1990s. HFC-134a is not an ozone depleting refrigerant, but like CFC-12, is a potent greenhouse gas that contributes to climate change.

Today, automobile manufacturers are transitioning to new, climate friendly alternative refrigerants.

EPA's Significant New Alternatives Policy (SNAP) Program identifies alternatives that pose lower overall risk to human health and the environment. Under SNAP, EPA has listed three low global warming potential refrigerants as acceptable for mobile air conditioning subject to use conditions: hydrofluorolefin (HFO)-1234yf, carbon dioxide, and HFC-152a. None of these alternatives deplete the ozone layer and all have significantly lower impacts to the climate system than CFC-12 or HFC-134a.

### Global Warming and Climate Change

The term climate change is often used interchangeably with the term global warming. Climate change is becoming the preferred term because it points to many changes, not just rising temperatures.

**Climate change** may result from:

- natural factors, such as changes in the sun's intensity;
- natural processes in the climate system, such as ocean circulation, and
- human activities that change the atmosphere's composition; for example, burning fossil fuels, removing large areas of forest or expansion of city areas.

**Global warming** is an increase in the average temperature of the atmosphere near the Earth's surface and in the upper atmosphere. In common usage, "global warming" often refers to the warming that can occur as a result of increased emissions of greenhouse gases from human activities.

**Greenhouse gases**, whether natural or man-made, reduce the amount of heat that can escape from the atmosphere. If too much heat is retained, the effect is similar to being in a garden greenhouse where the glass admits sunlight but traps the heat within.

Some heat-trapping gases occur naturally in the atmosphere: water vapor, carbon dioxide, methane, ozone and others. Natural processes within the atmosphere keep the gasses and the heat exchange in balance.

Man-made chemicals and emissions also affect the atmosphere, and many believe that the large volume released around the world is tipping the balance in the atmosphere and increasing the amount of heat held near the surface.

To describe how much effect each chemical may have in the atmosphere, scientists developed a rating index of "global warming potential" or GWP. It compares the behavior of each chemical against carbon dioxide, a chemical with very little effect and a GWP rating of 1. Chemicals with a high GWP contribute more to the problem than products with a low number.

**Environmental Impacts of MVAC Refrigerants**

Name	Global Warming Potential <sup>(1)</sup>	Ozone Depleting
CFC-12	10,900	Yes
HFC-134a	1,430	No
HFC-152a	124	No
HFO-1234yf	4	No
CO <sub>2</sub> (R-744)	1	No

*(1) Global warming potential values are from the IPCC Fourth Assessment Report: Climate Change 2007 (AR4).*

### NOTES:

---



---



---



---



---



---



---



---



---



---

## The Switch to HFC-134a Refrigerant

Starting with some 1992 models, and completed by the 1995 model year, HFC-134a replaced CFC-12 in vehicles sold in the U.S. Changes in system designs were required to assure that HFC-134a systems performed equal to CFC-12 systems. Some of these changes included new hose and seal materials compatible with HFC-134a, and the lubricants used with it. New hose and seal designs also reduced leakage.

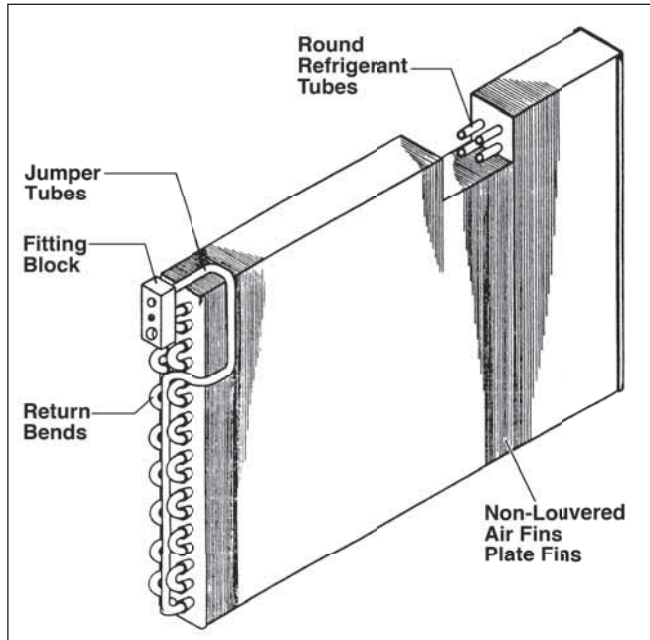

The most noticeable changes however, were redesigned condensers, which incorporated increased airflow to reduce system pressures at low speed operation and city traffic conditions. In general, condenser performance for HFC-134a systems increased by approximately 30% over that of CFC-12 systems, which resulted in comparable performance between the two refrigerants.

HFC-134a systems also required a new desiccant material. Desiccant, which absorbs moisture in the system, is located in the receiver/drier or accumulator, or integral in a cartridge or bag with the condenser.

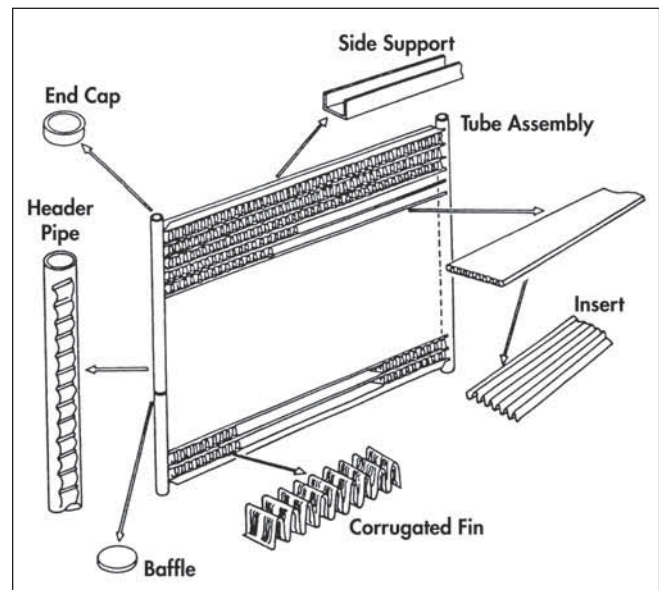

*The condensers used in HFC-134a systems are more efficient than the ones that were used in CFC-12 systems. The 3/8-inch tube-and-fin condenser shown on the top diagram is an example of the type that was used for many years in CFC-12 systems. The parallel flow/multi-flow condenser on the bottom diagram is representative of the type of condensers used in most HFC-134a systems.*

## SERVICING OF FUTURE MOBILE AIR CONDITIONING SYSTEMS

Concern about the environment has, and continues to spur changes in the type and amount of refrigerant used in mobile air conditioning systems. This has resulted in system design updates, new service procedures and equipment to reduce lifetime emissions.

The global automotive industry and the U.S. EPA have evaluated new replacement refrigerants that will affect the service of future systems.

### In Europe

In 2006, the European Commission adopted stiff new rules to control many sources of global warming. Vehicle manufacturers are working now to reduce tailpipe emissions, increase fuel mileage and change to an air conditioning refrigerant with a GWP below 150.

By European law, certain new vehicles were required to begin using a replacement refrigerant by 2013, and HFC-134a has been eliminated from use in almost all passenger vehicles since January 1, 2017. However, the legal requirements do not specify the exact refrigerant to be used — only that whatever is chosen must be less damaging to the atmosphere.

### In the U.S.

What Europe chose has had an effect in our country as well. Vehicle makers around the world sell their products in many countries. Also, switching to a low GWP refrigerant provides credits for vehicle manufacturers toward the 2016 EPA mandate for a corporate fleet average of less than 250 grams per mile of CO<sub>2</sub>.





A SNAP rule effective July 20, 2015 makes the use of HFC134a unacceptable in new light-duty systems as of Model Year (MY) 2021, except where allowed under a narrowed use limit through MY 2025 (see page 52).

### HFO-1234yf Systems

The chemical HFO-1234yf and the motor vehicle air conditioning (MVAC) systems using it are different from R12 and R134a systems. Vehicles using the new refrigerant require new service procedures and new shop equipment. A technician will need the skills to recognize the differences between refrigerants and how to service or repair each one properly and safely.

**EPA is not requiring the use of HFO-1234yf or any other alternative for MVAC systems. Automobile manufacturers have the option of using any refrigerant listed as acceptable for this end-use, so long as they meet any applicable use conditions.**

The U.S. EPA has listed HFO-1234yf as “Acceptable, subject to use conditions, for use in newly manufactured passenger cars, light-duty trucks, medium-duty passenger vehicles, heavy-duty pickup trucks, and complete heavy-duty vans.” EPA also noted, “This determination does not apply to the use of HFO-1234yf as a conversion or retrofit for existing MVAC systems. In addition, it does not apply to the use of HFO-1234yf in the air conditioning or refrigeration systems of heavy duty trucks, refrigerated transport, or off-road vehicles such as agricultural or construction equipment.”

The required conditions are that this refrigerant may ONLY be used in new vehicles with components specifically designed for it. The new system designs will include some new components and materials.

The new chemical has other uses in other industries, but when it is used as a refrigerant it is designated R1234yf. Chemically, it is a hydrofluoroolefin, and contains the elements carbon, hydrogen and fluorine. Its full chemical name is 2,3,3,3-Tetrafluoroprop-1-ene.

HFO-1234yf is classed by ASHRAE as A2L - Mildly Flammable. It can ignite under certain circumstances. The refrigerant HFO-1234yf is similar to, but not the same as, R134a. It has been developed and tested by its manufacturers, independent laboratories, vehicle manufacturers, industry study groups and government agencies.

It has passed a variety of tests for human exposure risk and toxicity, flammability, environmental damage and suitability for use in vehicles. Various properties of this chemical have been evaluated by SAE International,

U.S. EPA, JAMA (Japan), ASHRAE, and the European Alliance. The chemical has been found acceptable for use by many governments and regulating bodies, and is listed on the U.S. EPA SNAP list of acceptable refrigerants, the AIHA-WEL list (American Industrial Hygiene Assn. – Workplace Environmental Exposure Limit), and in the European REACH program.

This chemical is NOT a “drop-in” refrigerant or one that should be used in other systems. Systems designed for HFO-1234yf should only be charged with that refrigerant. Systems designed for other refrigerants should only use those correct products.

**See Best Service Practices for HFO-1234yf Systems, beginning on page 42.**

### R-744 (Carbon Dioxide) Systems

To meet the European low GWP refrigerant requirements, vehicle manufacturers have worked to develop mobile air conditioning systems that use carbon dioxide (R-744) as a refrigerant. R-744 has the lowest GWP value of new refrigerants being considered. Carbon dioxide systems will require different types of components compared to R134a systems. R-744 systems operate at pressures 5 to 10 times higher than R134a and R152a systems.

Carbon dioxide is hazardous, and therefore, also requires system design features to address safety for vehicle occupants and service personnel. In addition, new service equipment and service procedures, as well as specific training, would be required for technicians servicing R-744 systems.

**Standard J2683: Refrigerant Purity and Container Requirement for Carbon Dioxide (CO<sub>2</sub>/R-744) Used in Mobile Air Conditioning Systems**

*Issuing Committee: SAE International Interior Climate Control Fluids Committee*

This SAE Standard applies to Carbon Dioxide R-744 refrigerant used to service motor vehicle passenger air conditioning (A/C) systems designed to use CO<sub>2</sub> (R-744). Carbon dioxide (R-744) when used as a refrigerant in mobile air conditioning systems shall contain an odorant as an identification of refrigerant leaking from the system. Hermetically sealed, refrigerated cargo systems are not covered by this document.



## HFC-152a Systems

HFC-152a is another refrigerant that meets the European Community's requirements. HFC-152a has similar operating pressures to HFC-134a. However, HFC-152a is flammable, so its use would also require system design features to address vehicle occupant and service personnel safety.

Two types of HFC-152a systems have so far been demonstrated; the direct expansion type and the secondary loop type.

The direct expansion type is just like an HFC-134a system, except that to address the flammability issue, system safety features are required. The secondary loop type incorporates a direct expansion refrigerant circuit located in the engine compartment with a chiller that cools a non-flammable liquid. The non-flammable liquid is circulated to a cooling coil that replaces the evaporator. This provides isolation between the flammable refrigerant and the passenger compartment.

New service equipment, procedures, and training, would be required for technicians servicing HFC-152a systems.

One of the lesser known refrigerants, R-152a can actually be found quite easily. Its chemical name is difluoroethane, the propellant often used in asthma inhalers and computer duster spray cans, amongst other uses. It's also a very effective and efficient refrigerant which has undergone extensive practical study by some of the world's largest car makers and A/C system manufacturers.

The biggest drawback to using R-152a is its ASHRAE flammability rating, which is A2. This means that it will

burn when ignited. Therefore, for safety reasons, prototype systems which are currently being developed use a design called a Secondary Loop A/C system.

## Other Alternative Refrigerants

Other chemicals being developed as replacement refrigerants with low GWP ratings may also enter the marketplace. The systems in which they are intended for use will be specifically designed to use these new refrigerants.

### CAUTION

Technicians working on mobile air conditioning systems should be keenly aware of the characteristics of the refrigerants they are working with for their own safety, and that of their co-workers and customers.

**R-1234yf Systems:** These systems are classified by ASHRAE as A2L – Mildly Flammable. See pages 43 and 44 for specific safety procedures.

**R-744 (Carbon Dioxide) Systems:** These systems operate at much higher pressures than R-134a or R-1234yf systems. Also, if a system with this refrigerant is overcharged and a leak into the passenger compartment occurs, the concentration could exceed the health based limit for carbon dioxide (CO<sub>2</sub>). Concentrations may not exceed a short term exposure level of 3% or 30,000 parts per million (ppm) averaged over 15 minutes in the passenger free space; and the ceiling limit of 4% or 40,000 ppm in the passenger breathing zone.

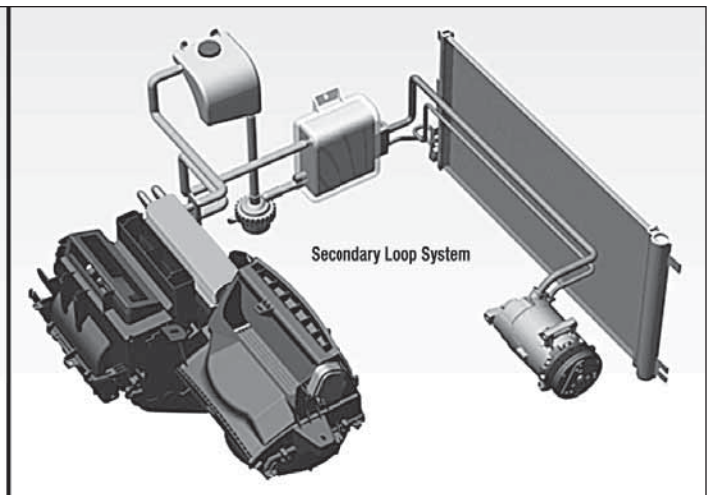
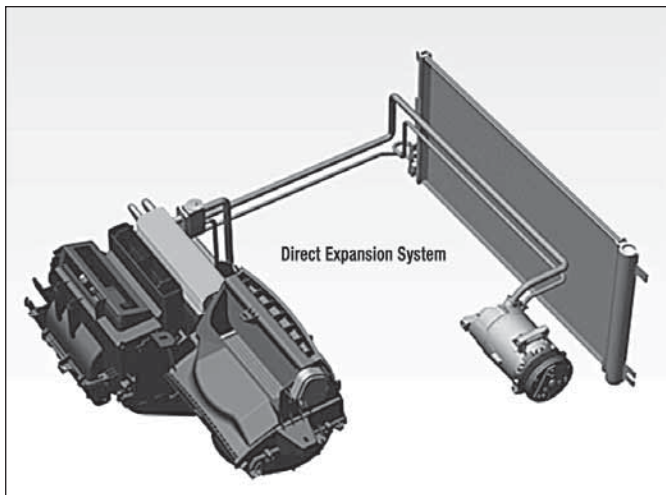

Most A/C systems are Direct Expansion, meaning the refrigerant directly expands within the evaporator that's located inside the passenger compartment. For safety reasons, systems designed to use R-152a will be Secondary Loop, instead using a refrigerant-to-glycol heat exchanger located inside the engine compartment. Chilled glycol will then circulate through a Cooler Core of sorts, to remove heat from the cabin.



## FEDERAL REGULATIONS AFFECTING MOBILE A/C SYSTEM SERVICE

Section 609 of the Clean Air Act gives the EPA authority to establish standards and requirements regarding the servicing of mobile A/C systems.

### Equipment Use

Since January 1, 1992, for CFC-12, and November 15, 1995 for HFC-134a and other mobile A/C refrigerants, any person servicing the mobile air conditioning pressurized refrigerant circuit must comply with the Clean Air Act and must use either refrigerant recovery/recycling or recovery-only equipment approved by EPA. Those working "for consideration" (receiving monetary value) who open the refrigerant circuit must be certified by an EPA-approved organization to legally use such equipment to service the system.

Persons working on their own mobile air conditioning system are not covered under this rule and can add refrigerant without being certified. It is illegal for any person to knowingly release or vent refrigerants (except CO<sub>2</sub>) during service, maintenance, repair and disposal. Such actions pose a risk to human health and the environment.

Fleets of vehicles, whether private, federal, state or local government owned, are subject to the regulations because the technicians performing the service are paid. Other examples of establishments covered by the regulations include, but are not limited to: independent repair shops, service stations, fleet shops, collision repair

shops, chain or franchised repair shops, new and used car and truck dealers, rental establishments, radiator repair shops, mobile repair operations, vocational technical schools (because instructors are paid), farm equipment dealerships and fleets of vehicles at airports.

### Technician Training and Certification Requirements

To become certified, technicians must pass a test demonstrating their knowledge in the use of refrigerant recovery/recycling equipment, the EPA's regulatory requirements, the importance of refrigerant containment and the effects of ozone depletion and environmental change.

### Overlap Between Sections 608 and 609 of the Clean Air Act

Section 608 of the Clean Air Act prohibits the venting of refrigerants, unless specifically exempted. CO<sub>2</sub> is the only MAC refrigerant that is exempt. This includes the scrapping/salvage of vehicles that have mobile A/C systems. Section 608 covers procedures involving motor vehicle (and certain other means of transportation) air conditioners (MVACs) that are not covered by Section 609, such as the disposal of MVACs. Following is information concerning specific areas where the overlap between these two sets of regulations may require clarification.

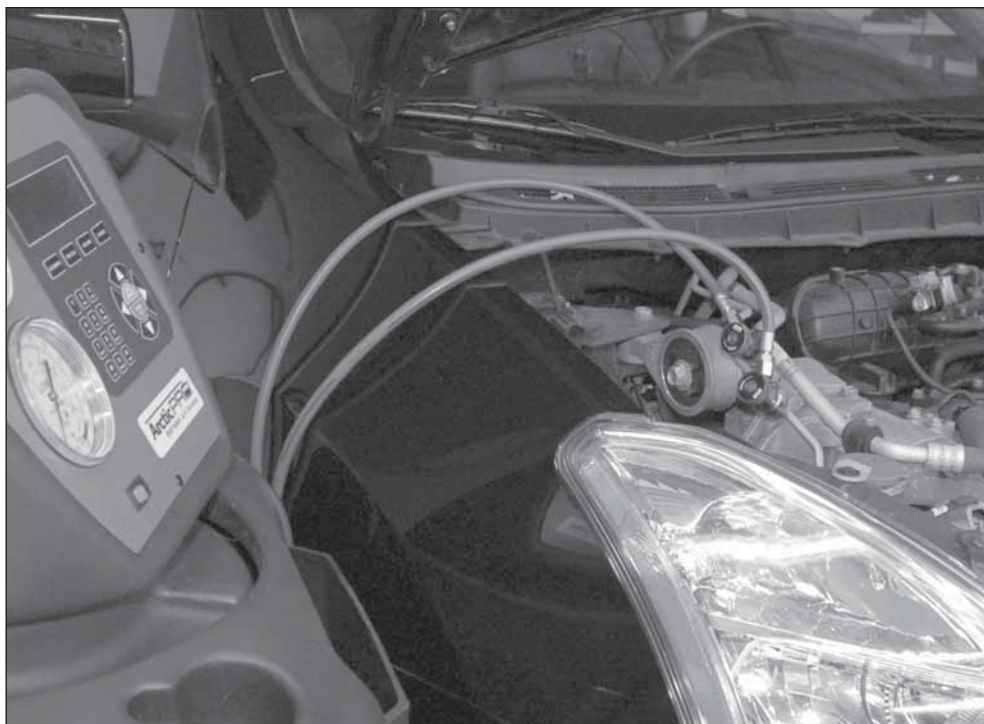

*Under Section 608 of the Clean Air Act, intentional release (venting) of any refrigerant is illegal unless the refrigerant is specifically exempted from the prohibition. CO<sub>2</sub> is exempt under 608 meaning that it can be legally vented. Although CO<sub>2</sub> may legally be vented, section 609 still requires that all MVAC systems be serviced through the proper use of EPA-certified refrigerant handling equipment. This requirement applies regardless of the refrigerant used in the MVAC system. This means that anyone servicing an MVAC system that uses CO<sub>2</sub> as the refrigerant would need to properly use EPA-certified refrigerant handling equipment.*





# CERTIFICATION TRAINING MANUAL

Section 609 of the Clean Air Act establishes standards specifically for the service of MVACs. MVACs are included in the definition of appliances under the stipulations put forth in Section 608; however, since their service and repair are regulated under Section 609, they are not subject to the servicing requirements put forth in Section 608.

Both regulations require that technicians become certified. Technicians who repair or service MVACs must be trained and certified by an EPA-approved Section 609 program. These programs are specifically designed to cover MVAC refrigerant recovery, recycling and charging equipment and procedures in accordance with SAE Standards, and Section 609 regulatory requirements. After completing a required training program, MVAC technicians must pass a test to become certified. These tests are different from the Section 608 certification tests.







Under Section 608, the EPA has established four types of certification for technicians that service and repair appliances other than MVACs. To be certified, technicians must pass a test applicable to the appropriate appliance type. Training and review classes for Section 608 are

voluntary; only passing the test is mandatory. The four categories of Section 608 certification are:

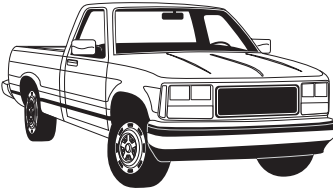
- **Type I:** Small appliances
- **Type II:** High-pressure appliances (except small appliances) and MVACs
- **Type III:** Low-pressure appliances
- **Type IV (Universal):** All appliances except MVACs

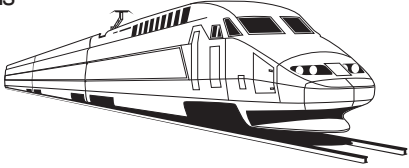
People who service or repair MVAGlike appliances (e.g. farm equipment and other off-road vehicles) can choose to be certified by either the Section 609 program or under Section 608 Type II. However, due to the similarities between MVAC and MVAGlike appliances, the EPA recommends that technicians servicing MVAGlike appliances consider certification under Section 609.

**Note: While buses using CFC12 or HCFC134a are MVACs, buses and other vehicles using HCFC22 as refrigerant are not classified as MVACs or MVAGlike appliances, but rather as high-pressure equipment covered under Section 608 Type II. Certification under Section 608 is also required to service cargo refrigeration equipment.**

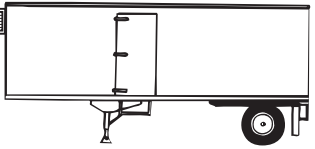
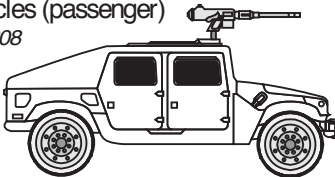
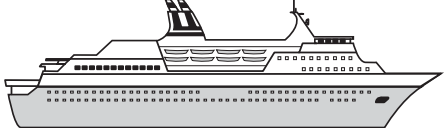
608 vs. 609		
MVAC (609)	MVAG-like (609)*	Appliance (608)
Passenger Cars and Trucks  	Buses 	Trains 
	Farm Tractors/implements 	Aircraft - Passenger** & Cargo **if HFC-134a system, 20 lbs. or less, then 608 or 609 
	Off-road Equipment 	Refrigerated Trailers 
	Military Vehicles (passenger) *if R-22, then 608 	Ship/Boat - Passenger & Cargo 

Do you need Section 609 Certification, Section 608 Certification, or maybe both? This chart will tell you which type(s) you need.







## Service Equipment Hoses

Hoses used with mobile A/C system service equipment must be equipped with shut-off valves. The valves may be either manual or automatic. The shut-off valves must be located within 12 inches (30 cm) of the “vehicle end” of the service hose, and most equipment manufacturers incorporate the shut-off valve in their quick-couplers. These automatically shut off the flow of refrigerant when the hoses are disconnected.

Fittings that are unique to individual refrigerants must be attached to the “vehicle end” of service hoses. Adapters for different refrigerants, different systems, or different service port designs may not be attached to service hoses, then removed and replaced with adapters for a different refrigerant.

### **Standard J2197: HFC134a Service Hose Fittings for Automotive Air Conditioning Service Equipment**

*Issuing Committee: SAE International Interior Climate Control Steering Committee*

This SAE Standard covers fittings intended for connecting service hoses, per SAE J2196, from mobile air conditioning systems to service equipment such as manifold gauges, vacuum pumps and air conditioning charging, recovery and recycling equipment. Due to similarities between English and metric thread sizes, a single, unique ACME thread fitting is specified. This fitting was recommended by the Compressed Gas Association (CGA), Connection Standards Committee Task Force as one which could be qualified to meet their requirements for use and safety in a time frame consistent with the introduction of R-134a. It was selected because its unique design would reduce the likelihood of cross-threading service hoses on R-12/R-134a refrigerant storage containers and service equipment. The high and low pressure hose in SAE J2196 requires the charge coupling (used to connect service hoses to vehicle access ports) to be an integral part of the hose assembly. To allow removal of the hose from the coupling for hose replacement only, a two-piece construction with a wrench tight connection is permitted.

## Equipment Certification

To comply with Section 609 of the Clean Air Act, recovery/recycling equipment must be certified to SAE specifications. Recovery/recycling equipment used for commercial refrigeration, and not certified to SAE standards, does not

meet the federal compliance requirements and cannot be used to service mobile A/C systems. To prevent refrigerant contamination, recovery/recycling equipment must only be used with one designated refrigerant.

## Equipment Registration

It is the responsibility of the recovery/recycling equipment owner, or another responsible person, to notify the EPA that they own approved equipment. The information in the following bullet points must be mailed to the EPA regional office for the state or territory in which the establishment is located.

- Name, address and telephone number of the establishment where the recovery/recycling equipment is located;
- Name brand, model number, year and serial number(s) of the equipment acquired for use at the above establishment.

The above information can be submitted on a plain sheet of paper, or can be submitted on the form the equipment manufacturers provide for this purpose. A copy of this form is provided on pages 57 and 58 of this manual. You may photocopy it for your use.

The person responsible for the equipment must sign the form. The person who signs is certifying that they are responsible for the equipment, that each individual assigned to use the equipment is properly trained and certified, and that the information provided is true and correct. The repair facility is required to file this certification only one time. ***The shop owner should keep a copy of the equipment certification on file.***

## Other Record Keeping Requirements

***Note: All records listed below must be retained for a period of three years.***

- As mentioned above, any person who owns refrigerant recovery/recycling equipment and provides service for monetary value, must have records verifying that all persons operating the equipment are certified.
- Any person who owns refrigerant recovery or recovery/recycling equipment must maintain records of the name and address of any facility to which refrigerant is sent.
- Any person who sells Class I substances (chlorofluorocarbons/ CFCs) or Class II substances (hydrochlorofluorocarbons/ HCFCs) for use as mobile A/C system refrigerants must prominently display a sign which states: “It is a violation of federal law to



sell containers of Class I and Class II refrigerant to any person who is not properly trained and certified to operate approved refrigerant recovery/recycling equipment.”

- Section 608 of the Clean Air Act requires that all persons who sell CFC and HCFC refrigerants must retain invoices that list the name of the purchaser, the date of the sale, and the quantity of refrigerant purchased. However, since the sale of small containers of CFC-12 is restricted to technicians certified under Section 609, these record-keeping requirements do not apply to the sale of small containers of CFC-12.
- Mobile A/C service facilities must allow an authorized representative of the EPA entry onto their premises, (upon presentation of appropriate credentials) and give the authorized representative access to all required records.

### Further Mobile A/C Service Rules and Regulations

- Every compensated technician that opens the refrigerant circuit must be certified. This includes technicians that only add refrigerant to “top off” a system. Facilities that typically only change or add fluids, such as lube-oil-filter operations, must have certified technicians and equipment.
- Section 608 of the Clean Air Act prohibits intentionally releasing (also called venting) ozone depleting refrigerants and most alternatives (including all HFCs, HFOs, and their blends) while maintaining, servicing, repairing, or disposing of MVACs and MVAC-like equipment. CO<sub>2</sub> refrigerants are exempted from the venting prohibition.
- It is permissible to only recover CFC-12, HFC-134a, HFO-1234yf and other refrigerants. In this circumstance, the refrigerant must be sent off-site for recycling – reprocessing (reclaiming) before reuse – or disposal.
- CFC-12, HFC-134a and HFO-1234yf removed from systems must be recycled before they can be reused, even if they are to be reinstalled into the same system from which they were removed. Blends must be recovered and sent off-site for proper disposal.
- Under federal law, it is legal to add refrigerant to a pre-existing leaking system. However, some states and local municipalities may have laws prohibiting this practice. It is the technician’s responsibility to determine if a more stringent policy is applicable in their location.

- It is not required under federal regulations to remove refrigerant from a leaking system. However, this action may be required under state and local laws. It is the technician’s responsibility to determine if a more stringent policy is applicable in their location.

Service facilities may adopt a policy to not add refrigerant to leaking systems, but the policy should be explained to the customer, including in the explanation the fact that the policy is not a federal or local governmental requirement.

Technicians should offer to fix leaks in air conditioning systems. It helps protect the environment and conserves refrigerant. In addition, eliminating leakage can prolong the life of the A/C system. It is not correct, however, to state or imply that leak repair is required under federal law. Doing so would constitute consumer fraud.

If a customer arrives with refrigerant in their A/C system, a technician removes it, then the customer declines any further services, the technician must return to the system the refrigerant it contained when it arrived, unless the customer agrees to its removal.

### Regulations Applicable to Vehicle Salvage and/or Disposal Facilities

Vehicle salvage and disposal facilities must remove refrigerants from salvaged or scrapped mobile A/C systems. Facilities that have certified recovery equipment can recover refrigerant at their facility and also move the equipment to other facilities to recover refrigerant. The salvage employee does not have to be certified to perform these operations.

If CFC-12, this refrigerant can be sold to technicians certified under Section 609. Until January 1, 2018, if HFC-134a, it can be sold to anyone wishing to purchase it. After January 1, 2018, if CFC-12, HFC-134a or HFO-1234yf, these refrigerants can only be sold to certified technicians (see page 52).

Section 609 certified technicians that are not employed by the salvage or disposal facility can remove CFC-12 and HFC-134a from mobile A/C systems at the salvage and/or disposal facility. There is no requirement to identify the purity of this refrigerant, or label tanks as containing refrigerant removed from vehicles at these facilities. It is important to keep in mind that refrigerant removed from vehicles at salvage and disposal facilities may be contaminated.

Salvage and disposal facilities must keep records documenting when and if someone not directly employed by them removed refrigerant from vehicles at their facility.



If applicable, they must also keep records documenting the sale of ozone-depleting refrigerants.

## A Further Word on Recovery-only Equipment

The operation of recovery-only equipment is similar to the recovery feature of recovery/recycling equipment. However, recovery-only equipment is designed for the sole purpose of removing refrigerant from a system; it does not recycle refrigerant for reuse. Before it can be reused, the refrigerant must be recycled through use of a recovery/recycling machine which meets the appropriate SAE standard, or sent off-site to be reprocessed to the appropriate Air-Conditioning and Refrigeration Institute (ARI) ARI 700 specification.

CFG-12 recovery-only (and recovery/recycling) equipment hoses have SAE 3/8-inch fittings; HFC-134a and HFO-1234yf recovery-only (and recovery/recycling) equipment hoses have quick couple fittings. Do not use adapter fittings with recovery-only machines or their tanks. Use of adapter fittings could result in contamination of refrigerant as well as A/C systems.

### NOTES:

---



---



---



---



---



---



---



---



---



---



---



---



---



---



---



---



---



---



---



---



---



---

### **Standard J2209: Refrigerant Recovery Equipment for Mobile Automotive Air Conditioning Systems**

*Issuing Committee: SAE International Interior Climate Control Service Committee*

The purpose of this SAE Standard is to provide equipment specifications for CFG-12 (R-12) recovery for return to a refrigerant reclamation facility that will process it to the appropriate ARI Standard (Air-Conditioning and Refrigeration Institute) or allow for recycling of the recovered refrigerant in equipment that is certified to meet the requirements of SAE J1991. Under the existing rule, the U.S. EPA requires refrigerant removed from a mobile air conditioning (A/C) system using recovery equipment certified to meet SAE J2209 can only be recycled using equipment meeting SAE J1991 that is owned by the same company or individual. It is not acceptable that the refrigerant removed from a mobile A/C system, with this equipment, be directly returned to a mobile A/C system. This information applies to equipment used to service automobiles, light trucks, and other vehicles with similar CFG-12 (R-12) systems.

### **Standard J2211: Recommended Service Procedure for the Containment of HFC-134a (R-134a)**

*Issuing Committee: SAE International Interior Climate Control Service Committee*

Refrigerant containment is an important part of servicing mobile air conditioning systems. This procedure provides guidelines for technicians for servicing mobile A/C systems and operating refrigerant recycling equipment. (This standard stresses the importance of refrigerant containment and offers guidelines on proper equipment use. Since this standard was issued, the industry has continued to develop service procedures to further enhance refrigerant containment. Many of those procedures and techniques are detailed, starting on page 11.)



## SERVICE PROCEDURES FOR MOBILE AIR CONDITIONING SYSTEMS

**Caution:** When using recovery/recycling/recharge equipment, while it is very important to follow the general service procedures outlined in this manual, it is also very important to follow your equipment manufac-

turer's instructions. Failure to follow these instructions could result in personal injury, damage to the equipment or A/C systems, or improper or inadequate refrigerant recovery, recycling and containment.

### SAFETY PRECAUTIONS & WARNINGS

1. ALWAYS wear eye protection when servicing air conditioning systems or handling refrigerant.
2. Avoid breathing refrigerant and lubricant vapor or mist. Exposure may irritate eyes, nose and throat. Acute exposure can result in asphyxiation. If accidental discharge occurs, ventilate the work area.
3. Do not allow refrigerants to come in contact with open flames and high-temperature surfaces. Decomposition is hazardous, and can occur if refrigerant is exposed to high temperatures (open flames, hot metal surfaces, etc.)
4. HFC134a is not flammable at normal ambient temperatures and atmospheric pressure. However, tests have shown it to be combustible at certain pressures and ambient temperatures when mixed with air under pressure in a sealed environment. Service equipment or vehicle A/C systems should not be pressure tested or leak tested with compressed air.
5. PAG lubricant is hygroscopic (absorbs moisture). Containers must be kept tightly closed.
6. PAG lubricant can be a skin irritant. Protective impervious gloves are required to prevent lubricant contact with the skin. To help avoid skin contact, mineral oil should be used to coat o-rings and seals prior to installation. Also, since PAG lubricants absorb moisture, using mineral oil reduces the potential for fitting corrosion.
7. PAG lubricants can cause damage to paint, underhood plastic parts, engine drive belts and coolant hoses. Care should be taken to prevent PAG lubricants from coming into contact with these items.
8. Failure to follow instructions provided by A/C system service equipment manufacturers could result in personal injury or equipment damage.
9. To prevent refrigerant cross-contamination, use separate service equipment for each refrigerant. Lubricant and refrigerant left in hoses and equipment can be a source of cross-contamination.
10. NEVER transfer refrigerants to a cylinder or tank unless it is Department of Transportation approved for refilling. DOT approval is indicated by the designation "DOT 4BA" or "DOT 4BW" stamped on a tank's collar (handle).
11. If a refrigerant tank is overfilled, it may explode. To prevent this from occurring, when transferring refrigerant into a tank, the safe filling level must be controlled by weight, and must not exceed 60% of the tank's gross weight rating.
12. NEVER perform service on recovery/recycling/recharge equipment (other than routine maintenance) without first consulting authorized service personnel. The removal of internal fittings and filters can cause the escape of refrigerant under pressure.
13. NEVER perform maintenance or service on recovery/recycling/recharge equipment with the unit plugged into electric power unless directed otherwise.
14. Avoid using extension cords with recovery/recycling/recharge equipment. If this is unavoidable, use a minimum length, 3-wire (No. 14 AWG minimum) cord with a ground circuit. To prevent shock hazards and reduce the risk of fire, make sure the extension cord is in good condition (not worn or frayed) with the ground circuit intact.
15. Recovery/recycling/recharge equipment often contains parts that may produce arcs or sparks. Do not use this equipment near flammable liquids or vapors.
16. Fuel injection systems on some vehicles contain a service port the same size as one of the R12 A/C system service ports. Be careful not to attach A/C service equipment to a vehicle's fuel injection system.

Additional health and safety information may be obtained from equipment, refrigerant and lubricant manufacturers. Refer to their instruction manuals and Material Safety Data Sheets.





## Maintaining Your Refrigerant Recovery/ Recycling/Recharge Equipment

Recovery/recycling/recharge equipment should be checked frequently to ensure that no leaks exist within the internal refrigerant flow circuits, as well as the external hoses and seals. Filters/driers must also be replaced in accordance with the machine manufacturer's specifications (check the equipment manual for filter location). Regular maintenance of your recovery/recycling/recharge machines helps to ensure that the SAE standards of purity for recycled refrigerant are met.



*R/R/R machine internal plumbing must be periodically checked to make sure no leaks are present.*

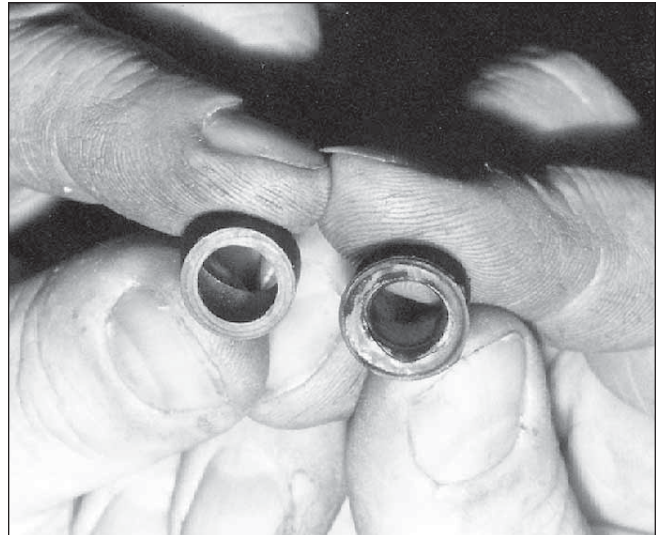

*The seals on service equipment hoses must be frequently inspected for damage and replaced when necessary. This shows a comparison between a new seal (left) and a used one that is swollen and distorted (right).*

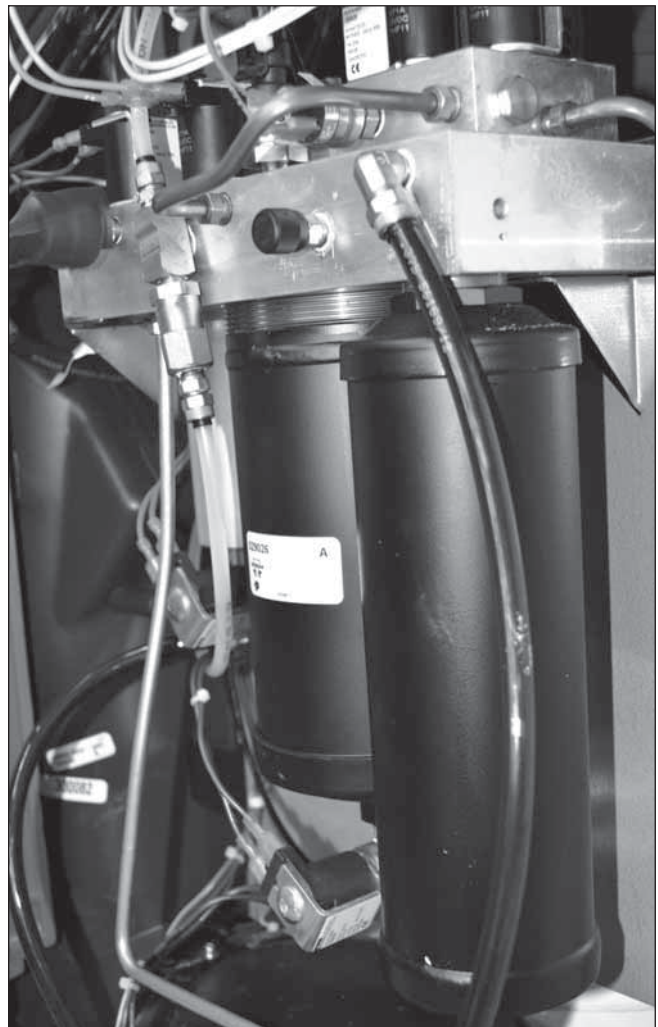

*R/R/R machine filters/driers must be replaced in accordance with the machine manufacturer's recommendations.*





## REFRIGERANT RECOVERY AND RECYCLING PROCEDURES

### Before You Begin . . .

#### Refrigerant Identifiers

A refrigerant identifier can help alert you to air conditioning system refrigerant contamination problems. The service industry and EPA strongly recommend, but do not require the use of this equipment. You can also use an identifier to help confirm what type of refrigerant is in a container. The identifier should conform to the specifications outlined in SAE J1771, J2912 or J2927; this assures that the unit correctly identifies refrigerants. (Note: only J1771 units are required to identify CFC12.) Keep in mind however, that even the best identifier may not be capable of indicating all of the possible combinations of chemicals that may be in an A/C system or storage tank.



*While not required by federal law, the use of a refrigerant identifier is strongly recommended. It can help you determine if a vehicle contains contaminated refrigerant that you would not want inside your recovery machine. Identifiers can also provide an accurate indication concerning the amount of air that may be in an A/C system or storage tank. Some state or local laws may require their use.*

#### Ensure System Integrity

As a first step in service, always perform a visual inspection to spot obvious problems. Since the service port caps serve as the primary seal for the service ports, make sure that each service port in the system has a cap installed, and that the caps' seals are not damaged. Missing or damaged service port caps are major leak sources. After service on the system is completed, make sure that each service port has a cap reinstalled, and that all of the caps seal properly.

Prior to system disassembly, look for the presence of refrigerant oil on adjacent surfaces that could be a sign of a leak. Clean all dirt, grease and debris from and around connection points before servicing. Carefully inspect refrigerant connections, joint seals and seal surfaces for signs of wear, deformation, contamination or damage. When reassembling components, ensure proper alignment of male/female connections and seal, then tighten the connection to the correct torque value specified by the manufacturer.

#### Check for Pressure in the System

It would make no sense to attempt refrigerant recovery from a system that contains no refrigerant. Because of this, always check to see if the system has pressure by



*Before connecting service equipment, always perform a visual inspection of the A/C system to spot any obvious problems.*

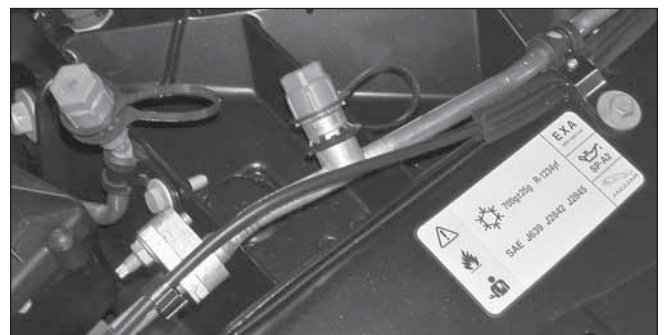

*The caps are the service ports' primary seal against refrigerant leakage. Always make sure that every service port has one in place.*



connecting a pressure gauge to a system service port before starting a recovery process.

If a system contains no pressure, it is a safe assumption that the refrigerant has leaked out, and one of your first steps in service should be trying to track down a leak or leaks in the system.

If a system has some pressure but contains an unknown amount of refrigerant, additional refrigerant can be added to check the system's operation. To provide the best system diagnosis, it is advisable that the current refrigerant be recovered and the factory charge amount be added.

### The Effect of System Design on the Refrigerant Recovery Process

When refrigerant is removed from the system, the lowering of pressure results in some of the system components becoming cooler. This component cooling effect makes complete refrigerant removal in a short period of time more difficult.

To remove as much of the refrigerant as possible during the recovery process, systems equipped with orifice tubes and accumulators may require more time than systems equipped with expansion valves/receiver-driers.

During the recovery process, as the system is drawn into a vacuum, and pressure in the accumulator is lowered, the accumulator becomes very cold, with external frost sometimes visible on the accumulator. This makes it even more difficult to extract remaining refrigerant from it. If all or most of the refrigerant has not been removed and the refrigerant lines are disconnected, a sudden release of refrigerant and oil can occur.

Heating the accumulator with devices such as a hair dryer or electric heating pad will raise the pressure in the accumulator and reduce the amount of time necessary for refrigerant removal.

When recovering refrigerant from any mobile A/C system, continue the recovery process until the system has been reduced from a pressure to a vacuum. At this point, pause operation of the recovery machine for five minutes, and check A/C system pressure. If pressure has risen above vacuum, additional recovery is required to remove remaining refrigerant. Repeat the recovery process until the vacuum remains stable, without rising, for two minutes.

Many recovery/recycling machines have a built-in five-minute wait period after the system is first drawn into a vacuum, and if a rise in system pressure is sensed, will automatically repeat the recovery process until the system will remain at a stable vacuum.

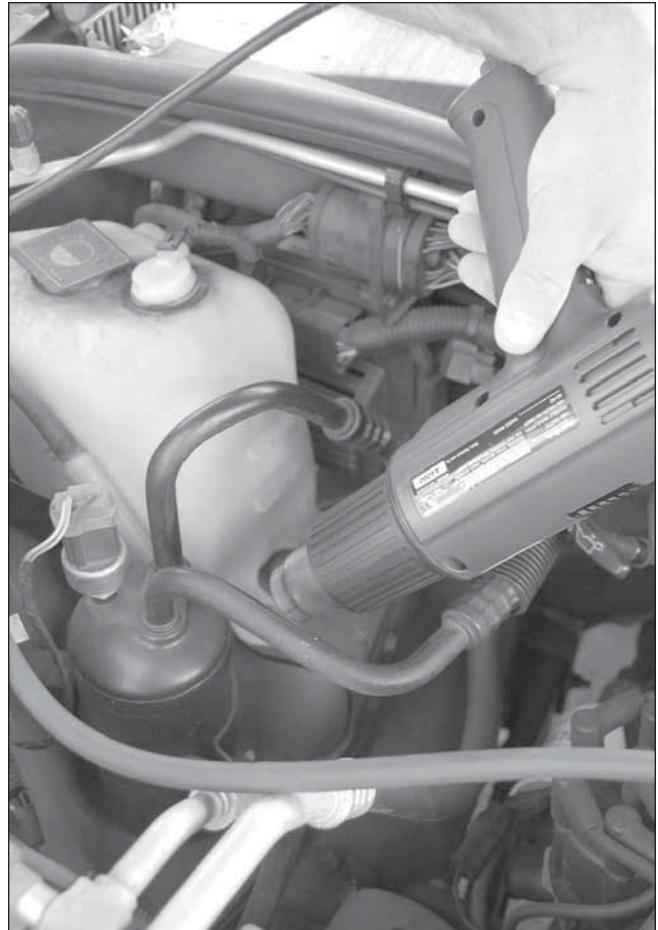

*Heating an accumulator during refrigerant recovery is a good idea. The heat will raise pressure inside the accumulator, allowing it to more easily outgas refrigerant it contains. This will reduce the amount of time necessary for more complete refrigerant removal.*

#### **Cautions:**

- 1. At no time should an open flame torch be used to heat the accumulator.**
- 2. All refrigerant must be removed before opening any of the system's connections.**

### More Complete Refrigerant Recovery

The amount of refrigerant you can recover from a system depends on how much is in the system, of course, but also ambient temperature, the technique you use, and the performance of the recovery machine itself. When you draw out the refrigerant, the vacuum lowers the temperatures in the system; the oil chills and forms a virtually impenetrable blanket over some of the refrigerant.

To recover as much refrigerant as possible, warm up the system's underhood components with engine heat and, as already mentioned, apply external heat to the accumulator (if the system has one).



## Engine Pre-Heat for Refrigerant Removal Procedure

The following procedure will aid in refrigerant removal when the work area is cool and J2210 and J1732 recovery equipment is being used. In general if the work area is warmer than 90° F (32° C) this procedure is not required.

*Recovery equipment certified to J2788, J2810, J2843, J2851, J3030 do not require this pre-warming procedure.*

### REMOVAL PROCEDURE

#### 1. A/C System Controls

- ⚠ Compressor clutch off
  - Turn clutch off or remove electrical connection
- ⚠ Set panel system controls
  - Outside air (not max)
  - High fan speed
  - Airflow panel outlets
  - ATC Systems: Set temperature mid range
    - Check to make sure system is on outside air, drawing air from vehicle cowl air inlet area

#### 2. Vehicle hood open to allow warm engine air to enter cowl inlet to A/C system

- ⚠ Operate engine idle condition
  - Neutral (park) with parking brake applied
  - Depending upon engine compartment temperature:
    - Run engine to warm up A/C system components for 15 minutes
- ⚠ After idling engine for 15 minutes (hot condition)
  - Stop engine and then turn ignition to on position allowing operation of:
    - A/C fan high; system on Outside air
    - When applicable – Operation of electric engine cooling fan to circulate air in engine compartment
    - Do not change any control or conditions listed in steps 1 and 2 above
    - Start refrigerant recovery process
- ⚠ When refrigerant recovery is completed, including the required 5 minute recheck for system pressure (system refrigerant out gassing), shut vehicle and equipment off.

Tests performed for an SAE research program indicated that you can remove a higher percentage of the refrigerant by applying heat and performing recovery after the early morning ambient chill has gone.

There are also differences in the percentage of refrigerant that's recovered using best practices versus short cuts. A single "pull" on a cool morning might remove 60% of the charge, whereas a careful procedure, using heat to promote outgassing, might remove the over 90% that is necessary for accurate service.

### Improperly Recycled Refrigerant

It is important to make sure that recycled refrigerant does not contain air (non-condensable gas) in excess of allowable amounts. If recycled refrigerant contains too much air, high system operating pressure will occur. This will result in loss of air conditioning performance and possible system damage.

Properly operating recovery/recycling equipment will remove excess air. Many newer R/R machines have an automatic air purge feature which, if working properly, should assure that its recycled refrigerant will not contain excessive levels of air. However, many older R/R machines require manual air purge.

Make sure you understand which type of air purge feature your machine has and follow its manufacturer's instructions to assure that proper air purging is taking place.

**Note: Refrigerant contamination, by air, chemical additives or other refrigerants, can cause system operating problems.**

### NOTES:

---



---



---



---



---



---



---



---



---



---





## System Lubricants

CFG12 systems use mineral-based lubricants. HFC134a systems use polyalkylene glycol (PAG) lubricants. Hybrid vehicles with electrically driven compressors use special A/C system lubricants.



Different HFC134a systems require the use of different oils. You must install the type and viscosity recommended by the system or compressor manufacturer. To find out the type you need to use, refer to the underhood A/C system information label, or look it up in a service manual or electronic information system.



A vehicle's A/C system information label lists the type of lubricating oil that the system requires.

To prevent damage to the compressor or system, it is imperative that the correct type and viscosity of lubricant (and correct amount of lubricant) is used in an A/C system. Too little, or the wrong viscosity oil can cause internal compressor failure. But too much oil can also cause problems. Too much oil can cause the compressor to “liquid slug,” possibly even hydraulically lock up. Too much oil can also result in reduced overall system performance. The excess oil can heavily coat the interior surfaces of the heat exchangers, insulating the refrigerant from those surfaces.

Do not mix lubricants. Use only the type of lubricant specified by the system manufacturer. The A/C system label will identify the vehicle, compressor or A/C system manufacturer’s recommended lubricant, often by an OE part number or designation. However, the label may not

list the lubricant’s viscosity. You may need to consult another source (such as a parts catalog or service information) to obtain the lubricant’s viscosity rating.

Recovery-only and recovery/recycling equipment will separate the lubricant during the refrigerant recovery process, so properly recycled refrigerant will not contain too much lubricant.

In general, recovery equipment will remove very little, if any, lubricant from a system. It is a design requirement of the equipment that the amount of lubricant removed during recovery must be measurable. This is usually (but not always) indicated by removed oil being collected in a transparent graduated container.

If a large quantity of lubricant was removed during recovery, the A/C system probably had a lubricant overcharge.

To replace any lubricant removed during a recovery process, use only new lubricant of the type and viscosity specified by the vehicle or compressor manufacturer. Lubricant removed during recovery must not be reused in the system. Used lubricant should be disposed of in accordance with federal, state and local requirements (visit [www.ecarcenter.org/ecartour.html](http://www.ecarcenter.org/ecartour.html) for more information on specific disposal requirements).



Here is a typical recovery machine’s oil recovery reservoir. It should be emptied before each recovery operation, then checked when recovery is completed to see how much (if any) oil was removed from the system during recovery. If oil was removed, that same quantity of fresh new oil of the type the system requires must be reinstalled in the system before it is put back into operation.



# BEST SERVICE PRACTICES FOR MOBILE A/C SYSTEMS

## SOURCES OF REFRIGERANT EMISSIONS

Motor vehicle air conditioning systems can release refrigerant into the atmosphere in a number of ways:

- Leaks from system part failures and seepage, which occur when a leak is not repaired and the system is recharged or “topped off.”
- Refrigerant released during various service procedures.
- Refrigerant released from service equipment, manifold gauges and equipment hoses.
- When using small cans to charge a system, refrigerant remaining in the can is likely to ultimately be vented. The refrigerant remaining in larger (30 pound) disposable containers that has not been recovered is also sometimes vented when they are scrapped.
- Collision or other types of physical damage.

### Checking Mobile A/C Systems for Leaks

The EPA and MACS recommend that leaking systems should be repaired. To pinpoint leaks in mobile A/C systems, MACS recommends using the SAE J1628 service procedure.

This requires the use of an electronic leak detector certified to SAE standard J1627, J2791 or J2913. As minimum criteria, J1627 electronic leak detectors are capable of identifying leakage rates of 0.5 ounces per year at a distance of 1/4 inch from the leak point.

Detectors which have the most sensitive detection levels will help identify smaller leaks. Manufacturers' service and maintenance procedures must be followed to ensure proper operation of the equipment.

SAE standard J2791 (covering HFC-134a) and J2913 (covering for HFO-1234yf) electronic leak detectors, requires improved performance compared to J1627 detectors. Detectors certified to this standard, have the capability of identifying leakage rates as low as 0.15 ounces per year at a distance of 3/8 inch.

The charts on the next page provide a comparison for different types of leak detection devices and methods.

### Using Electronic Leak Detectors

The following procedures are recommended by A/C system manufacturers to best identify system leaks, and are also an overview of the SAE J1628 leak detection procedure.

The system should first be visually inspected by looking for traces of oil on refrigeration system components. Oil traces can be indications of possible leak sites.



Your electronic leak detector(s) must be certified to meet the SAE spec (the detector should be labeled as such), and must be used in accordance with the procedures outlined in the SAE J1628 spec. We've provided an overview of J1628 under “Using Electronic Leak Detectors,” (this page) and in the sidebar on page 19.



Typical leak detector certification label. It shows that this leak detector meets the minimum performance requirements outlined in SAE standard J2791.







## Another (Big) Reason to Find and Fix Refrigerant Leaks

Loss of refrigerant can reduce oil circulation – even before the low pressure switch or other sensor cuts power to the compressor clutch. Clutchless compressors may operate until a catastrophic failure occurs.

If a vehicle comes into your shop with a failed compressor and the system is low on refrigerant, just replacing the compressor is not going to fix the apparent leak. It is important to determine if there were multiple leak sources.

### Three Questions about Electronic Leak Detectors

#### 1. What conditions can affect the ability of electronic leak detectors to find leaks?

*Dirt and moisture coming in contact with the detector's probe tip can be hindrances when it comes to electronic leak detection. Distance from the probe to the leak site and windy environments also dramatically reduce detectors' abilities to pinpoint leaks.*

#### 2. What should a technician look for when purchasing an electronic leak detector?

*Technicians should look at the type of sensor technology used, and whether they are comfortable with the pros and cons of that type. They should also look at detector sensitivity, power requirements and battery life. Practical considerations like the length and flexibility of the probe in order to get into hard-to-reach places, what type of maintenance the unit requires and the unit's ease of use should also be considered.*

#### 3. What is the best way to use an electronic leak detector?

*High temperatures increase system pressure and therefore leak rates and actually help to find leaks. Conversely, cold temperatures, especially below 60° F, may reduce pressure/leak rate enough to make it difficult to find leaks.*

*According to SAE International, the best procedures for using electronic leak detection are detailed in SAE document J1628.*

- a. The document specifies that the user should perform leak detection in accordance with the equipment manufacturer's operating instructions and with the engine off.*
- b. In order to get the best performance, the system should be sufficiently charged with refrigerant to*

*maintain at least 50 psi. This may not be possible when the work area temperature falls below 55° F.*

- c. When working with the detector, care should be taken to not contaminate the detector probe. If cleaning of a part is necessary, do not use cleaners or solvents, which may contain substances that the detector will sense.*
- d. A visual inspection should be made for signs of lubricant leakage, damage and corrosion, and each damaged area should be inspected with the detector. Other areas to concentrate on are fittings, couplings, valves, service port caps, brazed or welded areas and component attachment points. Take care to inspect the entire system so no potential source of leaks will be missed.*
- e. To obtain the best chance of detecting the leak, move the probe no faster than 1-2 inches per second and hold it no more than 1/4-inch from the surface. If you find a potential leak, verify it by blowing shop air around the area and retesting.*
- f. Leak testing of the evaporator core is a challenging task. This is best accomplished by running the air conditioner blower on high for at least 15 seconds, and then turning the blower off. Wait for refrigerant to accumulate in the evaporator case (the manufacturer of the equipment will specify the amount of time). By inserting the leak detector probe into the blower resistor hole (if near evaporator), condensate drain or other appropriate opening (use a heater or vent duct as a last resort), you should be able to perform a refrigerant leak test.*
- g. When all service has been completed, leak test the system again to verify a complete repair.*

## NOTES:

## Another Tip on Using Electronic Leak Detectors

To isolate a suspected leak site in an area where air currents could dissipate leaking refrigerant, if possible, tape a piece of aluminum foil or plastic wrap around the connection or component. Allow some time for possible leaking refrigerant to collect in the plastic wrap or foil. Then, make a small hole in the foil or wrap at the lowest area possible and place the leak detector probe at the hole to check for the leak. Lastly, most electronic leak detectors require periodic maintenance to function properly. Refer to your leak detector's instruction manual for more information.

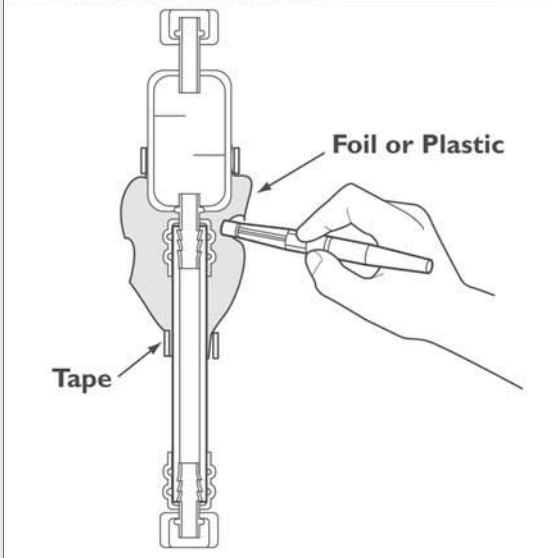

To help confirm a suspected leak, place aluminum foil or plastic wrap and tape it around the connection or component. If there truly is a leak, after a few minutes, refrigerant should accumulate inside the plastic wrap or foil. Make a small hole in the foil or wrap at the lowest point possible and place your leak detector probe at the hole. The detector will indicate "refrigerant found" if a leak is actually present.

## Using Dye to Find Leaks

Ultraviolet (fluorescent) trace dye systems are a popular choice for techs today in their efforts to hunt down elusive leaks. Not only are they an inexpensive and easy-to-learn method of locating leaks, they also have the advantage of giving the shop visual proof of a leak, which can turn into an interactive experience with the customer.



A typical UV dye leak detection kit contains dye, a dye injector (or some other type of tool to introduce dye to a system), a UV flashlight, and the correct goggles for the dye being used. Always wear the goggles to protect your eyes from the UV light. This kit also contains a special cleaner to remove traces of the dye after the leak is repaired.

## Dye Formula

Ultraviolet dye is a microscopic particulate suspended in a base fluid. This base fluid varies from manufacturer to manufacturer. This particulate and base fluid, when introduced into the refrigeration system, mixes with the lubricant and is transported throughout the A/C system. When a leak occurs, this particulate seeps out and leaves a stain on the outside of the component. This stain is then visible when a specific type of UV light is cast upon it.

Dye manufacturers stress that the purity of the dye and its thermal stability is crucial, as the dye will often see A/C system high-side temperatures of over 250° F, then cycle through evaporator at temperatures in the 30° F to 40° F range. The dye should not contain solvents of any kind that could damage system components or diminish the lubricant's properties (including viscosity).

To this effect, the SAE has issued standard J2297 to ensure that dyes are tested for system compatibility, and to make certain that they will not affect lubricant viscosity when used in proper doses. Make sure your dye meets this standard; there are some dyes that don't.





## How Much Dye Is Too Much?

It is important that dyes be safely and properly used. Excessive dye can result in compressor damage. Check the manufacturer's recommendation; the basic rule of thumb is 1/4 oz. per conventional system (up to 3 lbs. refrigerant or 10 oz. of oil).

## Lamps & Goggles

Most manufacturers design their UV lamps to work best with their own dyes (so the dye particles fluoresce with their lamp for the best wavelength), and use a reflector and lens to direct and filter the light properly. The UV lamp should also be UL-listed.

The coloration of the special yellow glasses that come with most UV dye leak detection systems enhance the dye's fluorescence and also protect your eyes from UV rays. UV rays are harmful to your eyes, and you should not stare at a UV lamp, just as you would not stare directly at the sun.

## Before You Begin Using UV Dye to Find Leaks

Always start with the dye manufacturer's instructions. They vary slightly, but the process is pretty straightforward. Also, first check to see if there is factory-installed dye in the A/C system. To prevent damage, dye should not be added to a system unless the vehicle manufacturer has approved the specific product.

## Choosing Your Delivery System

A MACS survey found that technicians did not have a consensus on the best way to install dye into A/C systems. It seems that techs are using just about every method, from in-hose dye canisters to caulking gun-type/syringe-type injectors, to simply pouring dye into an open system.

No matter which delivery method you choose, make sure you have a full refrigerant charge to allow the dye to thoroughly circulate in the system.

Add the dye, then let it circulate. Refrigerant escapes at the leak point as gas, but the dye is brought to the leak site with the lubricant, remaining behind so you can see it glow under a UV lamp.

## Looking for Leaks

When scanning the system with your lamp, put on the supplied glasses and examine all fittings, lines and components. A helpful trick is to use a mirror to reflect the UV light underneath the components. If you don't have

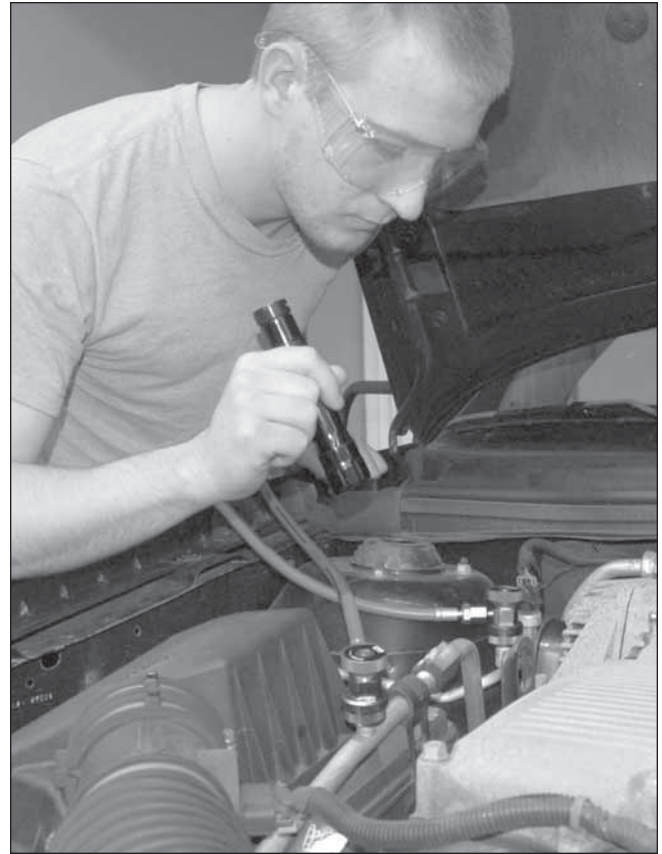

*Like this technician, always be sure to wear the special goggles that came with your UV dye leak detection kit. Not only do they protect your eyes from the UV light, they also make dye traces at leak sites stand out better.*

space for a mirror, then use a clean rag to wipe underneath the component and hold the rag under your lamp.

How much time should it take for the leak to appear? Dye makers say that the dye could take anywhere from a few minutes to a few days to show up at the leak site(s), so don't expect the dye to show up immediately every single time. The length of time depends on the size and location of the leak.

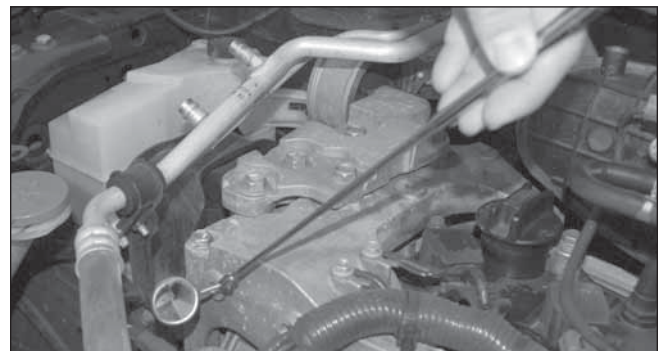

*You can use a mirror to reflect the UV light underneath components in hard to see locations. If dye is present at a leak site, you should see it glowing.*



In cases where a leak does not become readily apparent, you might want to consider instructing the customer to drive the car and use the A/C for a week or so, then bring it back so you can look for visual evidence of leakage. Do not let the customer run the car for months before coming back for their inspection and expect to see dye traces. Some of these dyes will wash off or lose their fluorescence over time.

After all system leaks have been identified, and the necessary repairs completed, the system should again be thoroughly leak tested.

You should find that using an electronic detector, along with ultraviolet dye, will often lead to great leak detection results.

## Flushing A/C Systems

Most A/C system manufacturers recommend that flushing not be performed. Open vent flushing often will not remove debris from a system. Connecting flush equipment to the system service ports, even with the valve cores removed, will not provide adequate system flushing, and may not result in the removal of debris and other substances. Many A/C system manufacturers consider the use of in-line filters to be an effective method of trapping debris.

Many A/C system and component manufacturers also have reservations concerning the use of solvents to flush systems. Other than possible ineffectiveness, the manufacturers' main area of concern is the fact that some solvent may remain in the system, because depending upon a solvent's boiling point, a vacuum pump may not remove all of it, even after a prolonged deep vacuum. This residual solvent can dilute the lubricant, which can lead to inadequate compressor lubrication and possible subsequent compressor failure. It could also possibly affect the chemical stability of the refrigerant, seals and hose materials.

Flushing compounds that are certified to SAE standard J2670, "Stability and Compatibility Criteria for Additives

and Flushing Materials Intended for Aftermarket Use in R-134a and R-1234yf Vehicle Air Conditioning Systems," have been tested for compatibility with A/C system components, and found to be compatible. However, this does not assure they will clean the component being flushed.

If a flush solvent is used, determine if the solvent is classified as a hazardous material. Dispose of it in accordance with local, state and federal regulations (visit [www.ecarcenter.org](http://www.ecarcenter.org) for more information on specific disposal requirements).

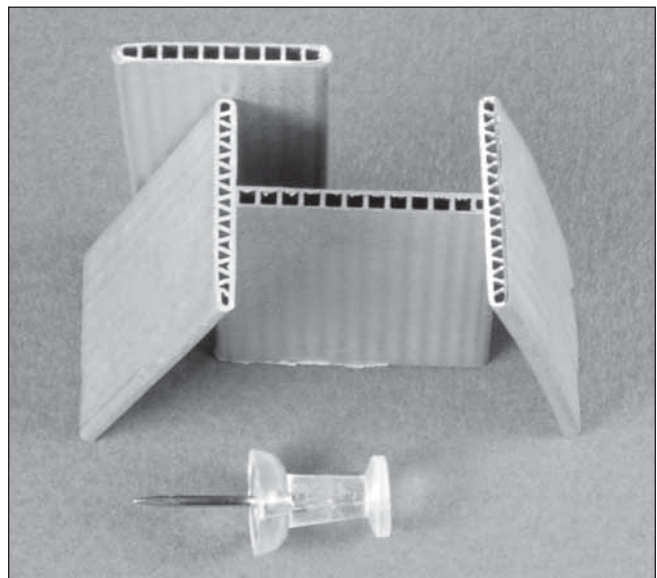
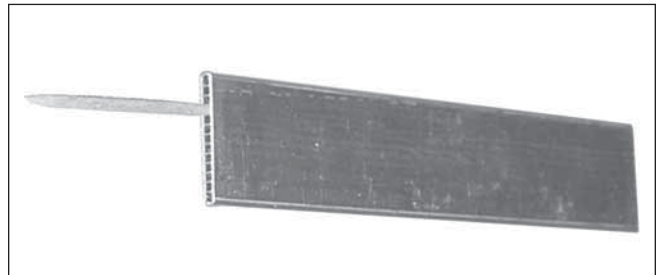

*Today's condensers have very tiny refrigerant multi-flow passages. Not only can't you even fully insert a toothpick into some of them, others are so small, a push pin will barely go in. This is why attempts to flush debris-dogged condensers are often not successful.*

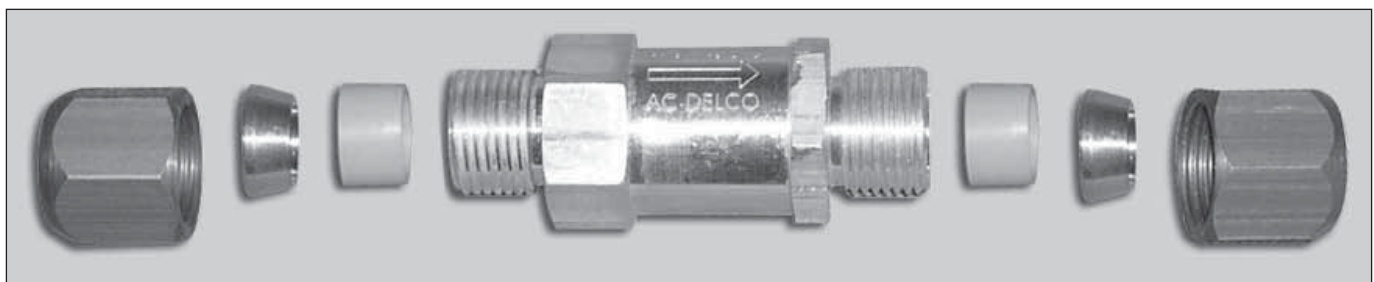

*In-liquid-line filters can be installed to trap debris that may be in an A/C system after it has suffered a catastrophic compressor failure. Filters of this type are available from a number of different A/C parts suppliers.*





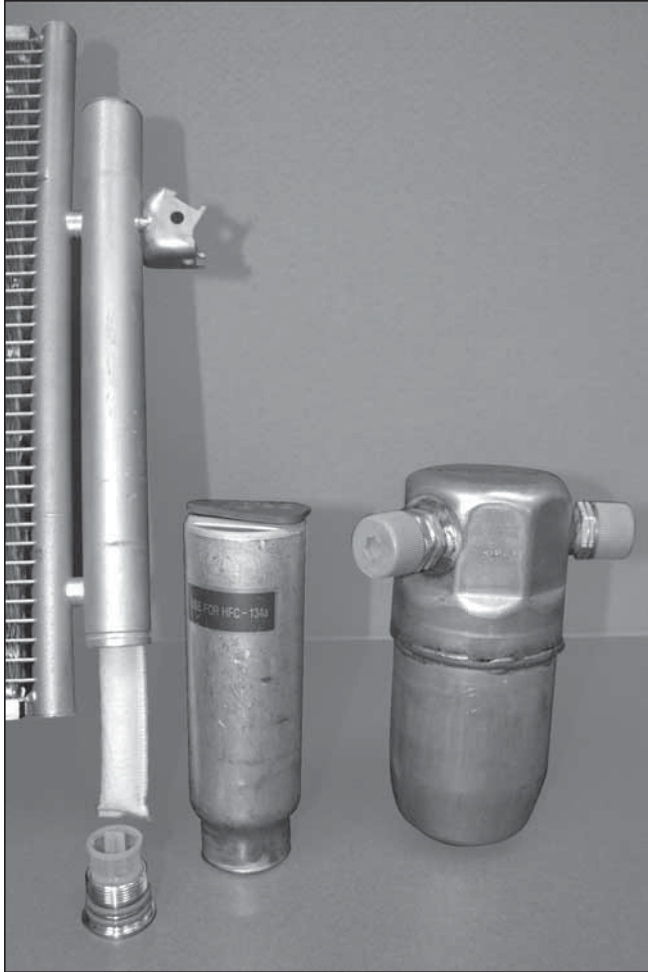

*The only way to remove significant moisture from a system is to replace the desiccant. Not only that, most compressor supplier's warranties require that the R/D, A/D, or desiccant be replaced when one of their compressors is being installed.*

So the bottom line is, even the best vacuum pump or recovery/recycling machine may not remove moisture through evacuation. The best assurance for control of excess moisture in the A/C system is to replace the desiccant.

### **Desiccant Failure**

When the refrigerant fittings (lines and components) are left un-capped and open to the atmosphere for an extended period of time, moisture can enter the system and result in the desiccant becoming saturated. It is advisable to keep the refrigerant circuit connections closed. If left open for a period longer than normal servicing activity, the desiccant should be replaced to provide moisture control. Systems left unsealed during extended vehicle collision repairs can result in moisture entry.

### **Properly Charging (and Recharging) Mobile A/C Systems**

To reduce refrigerant emissions, newer mobile A/C systems use less refrigerant. Because of this, today's systems are "critical charge." A critical charge system is one that is substantially less tolerant to variations in charge.

Undercharges can result in poor cooling, and even worse, poor lubricant circulation, which can lead to compressor failures. Overcharges can result in high operating pressures, which can also cause poor cooling performance, and even component damage. During hot weather, overcharged systems can shut down from the high side pressure control switch, due to high system pressure. Because of this, mobile A/C systems should only be charged with known amounts (by weight) of refrigerant. "Top-off" is no longer acceptable.

### NOTES:

---

---

---

---

---

---

---

---

---

---



## INCORRECT SYSTEM CHARGES – SOME REASONS WHY

Following are several more reasons that A/C systems end up getting charged with the incorrect amount of refrigerant.

### Making an Unintentional Mistake While Determining the Charge Amount

One reason for incorrect charge is making an unintentional mistake while determining the recharge amount. We sometimes see this because a vehicle manufacturer may find out long after a vehicle hits the street that they can get better A/C performance by increasing or reducing the system's charge. Or, there may have been a late change in a component that changes the charge spec, and that change was not made on the production line or on the vehicle's A/C system information label. So unless you have access to the latest service bulletins, you may not know about it.

Sometimes, new refrigerant labels are released. However, the odds that a new refrigerant label was actually attached to the vehicle are pretty remote, so checking for bulletins is important, including those for the not-so-new models that you're likely to be working on. Please keep in mind that the original charge was approved after testing, so if there's a new charge specification, it may not improve cooling under all conditions.

Also, some replacement condensers require a change in system charge spec, usually a reduction. These units are accompanied by instructions stating the new spec, as well as a new label that you are directed to place over the vehicle's original charge spec label. But does every tech always read all of the instructions that come in a box with a part? And even if so, once again, will every tech be diligent enough to affix the new label to the system? Always be on the lookout for these types of "outside the box" circumstances.

### Incorrect Calculation of Charge

Probably the easiest error to make is calculating pounds to ounces when there's a decimal involved. Here's a case history from a Chrysler minivan with a 3.13 lb. spec. An inexperienced tech charged 3 lbs., 13 ounces (3 lbs. x 16 for a total of 48 ounces, plus 13 equals 61 ounces) into the system. The correct amount is 50 ounces (0.13 lb. x 16 ounces is 2.08 ounces. Add in 48 ounces and the total is 50.08 ounces). So the results were about an 11 ounce overcharge, high discharge pressures and a puzzled technician.



*This machine is displaying the refrigerant charge amount in pounds and ounces. However, the label on every vehicle you service won't list the spec this way, so calculations will be needed; an easy place to make a mistake. (Some machines allow you to change the display units, but how many techs do so every time they can or should?).*

Or the reverse could apply: A label in ounces and a machine with a display in pounds (with the decimal). In this case, divide the total number of ounces by 16. Example: 50 divided by 16 equals 3.13 lbs. If your machine display is calibrated to a single decimal place, round off 3.13 lbs. to 3.2 lbs.

Still another calculation issue: grams and kilograms when you have a machine in pounds and/or ounces. There are 28.4 grams per ounce, and 2.2046 pounds per kilogram. The numbers are usually rounded off on spec labels, and if so, you won't have to worry about that level of accuracy.

### NOTES:

---



---



---



---



---



---



---





# CERTIFICATION TRAINING MANUAL

Volkswagen uses grams, so if you're converting to ounces, divide by 28.4. Example: 750 grams equals 26.4 ounces (just under 26-1/2 ounces) and the tolerance is plus (no minus) 50 grams, which equals 1.76 ounces (just over 1-3/4 ounces). So the precise range is 26.4 to 28.16 ounces.

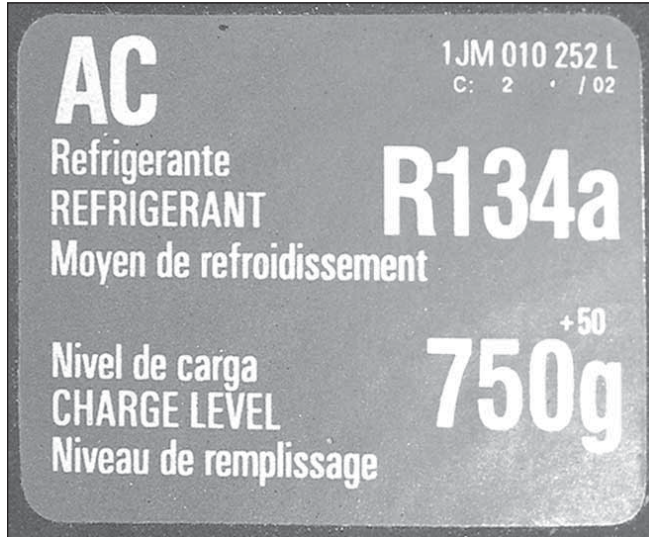

This Volkswagen label gives refrigerant capacity in grams, along with the plus tolerance (notice there's no minus, so the range is 750-800). In this case (although ounces are not listed), the specification tolerance of 50 grams can be rounded off to two ounces in any conversion.

### Conversion Chart

Ounces (oz) to pounds (lbs.)	.....	divide by 16
Pounds to ounces	.....	multiply by 16
Ounces to grams (g)	.....	multiply by 28.4
Grams to ounces	.....	divide by 28.4
Pounds to kilograms (kg)	.....	divide by 2.205
Kilograms to pounds	.....	multiply by 2.205
Kilograms to ounces	.....	multiply by 35.27
Ounces to kilograms	.....	multiply by 0.0284

Don't guess at U.S. to metric conversions. Use a calculator with this conversion chart (or an equivalent) for easy reference. And watch those decimal points.

Nissan uses pounds and kilograms, and if your machine is calibrated in pounds, please notice that the plus/minus tolerance is just 0.055 lb., which is 0.88 ounces, less than the 0.1 lb. on most decimal scales. Here again, take the range and aim for something within it. The specified charge is 1.21 lbs., so the range is 1.155 to 1.265 lbs. or 18.48 to 20.24 ounces.

Nissan is not totally consistent, at least not between the Nissan Maxima and the Infiniti M45 labels shown below. No tolerance is specified for Infiniti, just a single number.

It's a good rule of thumb to have a combination of equipment, and to work out a method that will always enable you to be able to charge within 5% of the specs.

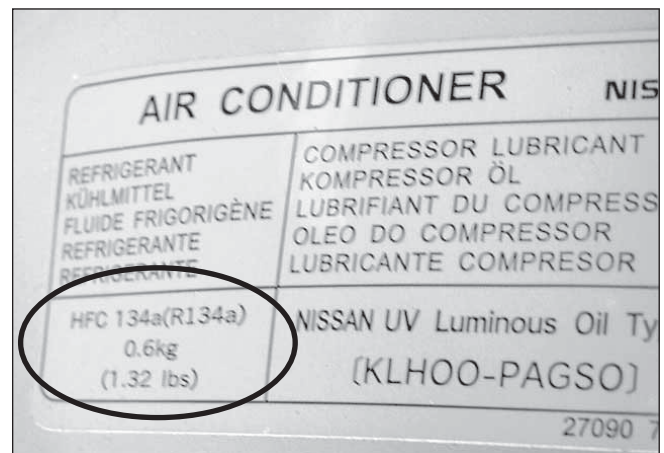

Infiniti (M45) label shows refrigerant capacity in pounds and kilograms, but with no tolerance listed.



Nissan (Maxima) label shows refrigerant capacity in pounds and kilograms, to two decimal places, and a tolerance to three decimal places.

### NOTES:



## Equipment Inaccuracy

The accuracy of shop equipment is a major issue.

- You might be using an old recovery/recycling/recharge machine. Its accuracy was never great in its best days. For example, the GMACR-4, the first dealer recovery/recycling/recharge machine for HFC134a systems, had a tolerance that was later discovered could go as high as plus/minus six ounces – a 19% variation in a two-pound system. At one time, that might have been close to acceptable. But since system capacities have dropped, and tolerances with them, you can encounter a performance problem if you're more than 5% off.
- Your scale, after years of use with little or no maintenance (and probably some abuse) is likely to have become inaccurate. Just because it's calibrated to one ounce or 0.1 lb. does not mean it's accurate to within one ounce or 1.6 ounces. There may be a big difference between the resolution of the digital display and the actual accuracy of the machine in delivering a charge.
- Some machines have a calibration feature for the scale, but if nothing else, you can put 33 pennies

on top of the jug and see if the scale can tell the difference. 11 pennies weigh one ounce, so with 33, there should be an increase in weight of at least 0.1 lb or two ounces, up to 0.2 lb. or three ounces.

R/R machines that meet SAE Standard J2788 will provide more accurate refrigerant removal and charging measurements, and provide a method for calibration of the scale.

SAE J2788 equipment provides the following measurement accuracy:

- The equipment must be capable of both indicating and recharging the system to within 15 g (0.50 oz) of vehicle manufacturer's specifications.
- If a scale is used in the machine, its manufacturer shall provide a method for the technician to check scale accuracy, and include any necessary accuracy-checking device (such as a calibration weight(s)) with the machine.

If you are having a problem with system performance or high system operating pressure, you may want to check if your equipment is charging the correct amount of refrigerant.

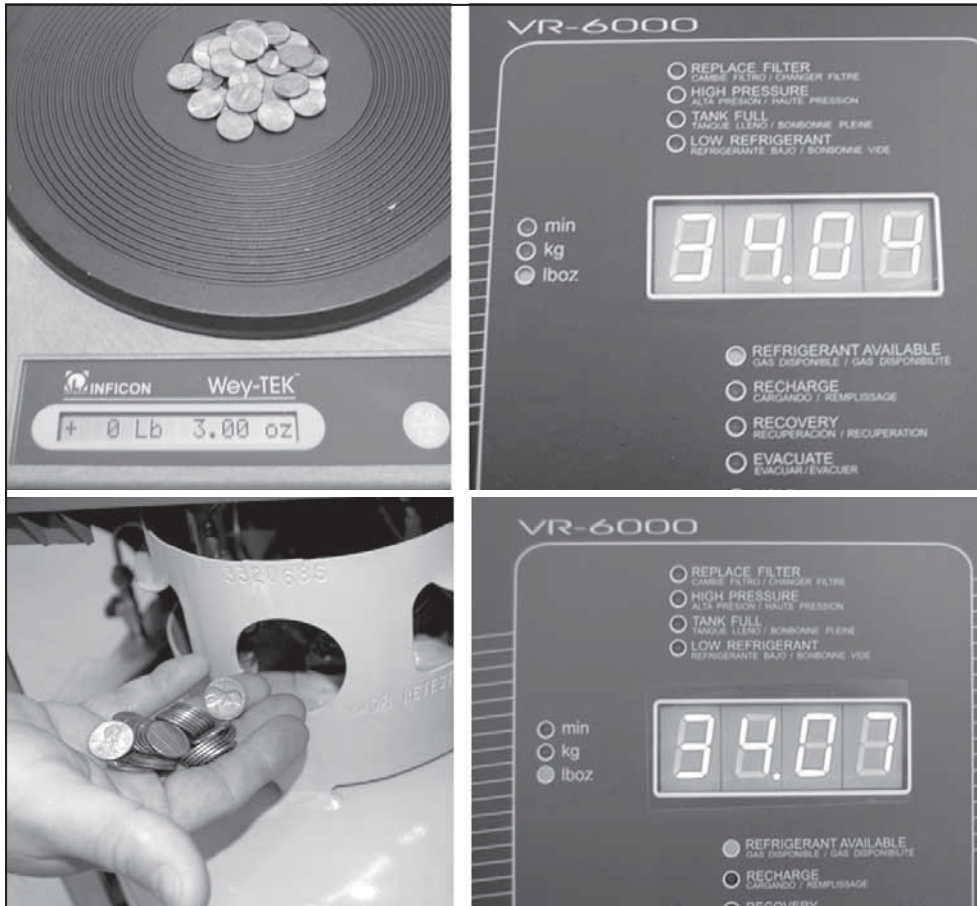

33 pennies weigh three ounces, and most shops can come up with them. They can be used to check the scale on your recharge machine. Place them on top of the refrigerant tank, and check the scale reading on the machine's readout. If the scale is working properly (within tolerance), the scale reading should show an increase in weight of at least 0.1 lb. or two ounces, up to 0.2 lb. or three ounces. If this does not happen, the scale needs either calibration or replacement. Anything else is not accurate enough for charging today's tight tolerance systems.

As you can see, the scale on this recovery/recycling/recharge machine is dead on. With 33 pennies placed on top of its refrigerant tank, its readout shows an increase in weight from 34 lbs., 4 oz. to 34 lbs., 7 oz.





## Not Accounting for the Refrigerant Inside the Service Hoses

A typical six-foot service hose holds approximately two ounces of refrigerant. The use of very long service hoses can cause a system to receive an overcharge if procedures are not followed that take hose length into consideration. Some charging equipment is programmable to allow for different hose lengths, which should assure an accurate charge. Refer to your machine's instruction manual for more information.

## Technician Doesn't Accept the Specs

It's amazing how many shops refuse to accept the factory spec, even if there's no bulletin to the contrary. Or somehow, they have acquired this idea that a little more refrigerant should be helpful. If they're unlucky, along with something else they do, or a part they replace, the system cools better – in the shop – than when it came in. Why is that unlucky? Because when it's really hot and the car is slow-moving in traffic, the high side pressure goes way up and the system shuts down. Then maybe some other shop gets the job, does a recovery and recharge, and enjoys a "phantom repair" at the expense of the first shop's reputation.

## Charging Systems with Small Cans or by Attempting to Use Pressure Readings

If you're charging with small cans, or even using 30 pound cylinders, but trying to charge a system going by gauge readings, or using any other method that does not involve accurately weighing the amount of refrigerant entering the system, **STOP!**

Pressure gauges are a diagnostic tool, but you can't use them to meter refrigerant into a system, and no vehicle or system manufacturer provides exact pressure specs for a precise charge. Even if you have reliable pressure readings, there isn't enough of a pressure difference to indicate over or undercharge.

System pressure readings, whether the system is operating or off, will not identify the amount of refrigerant in a system. The only way to assure that any given system's refrigerant charge is correct is to recover all of the existing refrigerant, perform a thorough evacuation and install a known amount. If you have a recovery/recycling only machine, consider purchasing an accurate digital scale, perhaps one with a solenoid-type dispensing valve.

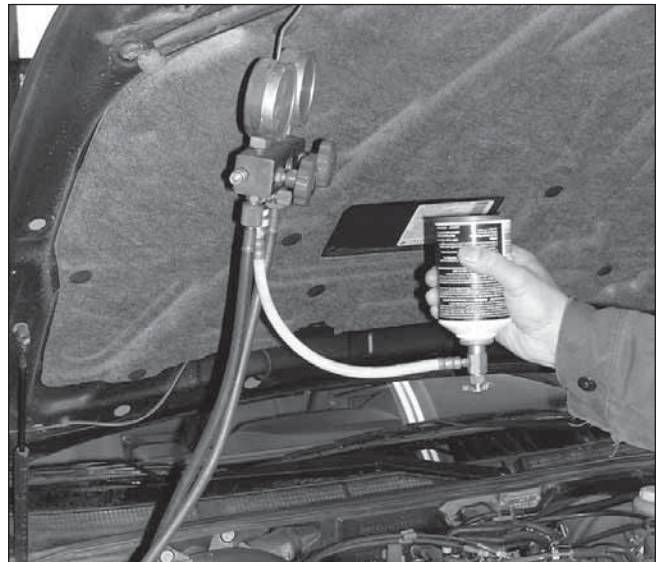

*Some technicians still attempt to use small cans and pressure gauge readings to charge systems, but accurate charging is not possible with this method.*

Notes: \_\_\_\_\_  
\_\_\_\_\_  
\_\_\_\_\_  
\_\_\_\_\_  
\_\_\_\_\_  
\_\_\_\_\_





## AVOIDING REFRIGERANT CONTAMINATION

Whenever you hear the term “refrigerant contamination,” the first thing you probably think of is mixed refrigerants. However, the most prevalent contaminant, particularly in recycled refrigerant, is air.

This section will provide tips on dealing with both of these problems; excessive amounts of air in refrigerant and cross-contaminated refrigerant.

### Three Questions on Air-contaminated Refrigerant

1. What problems are caused by excess air in a vehicle air conditioning system?

*Air, in excess of allowable amounts, can cause the system to operate at pressures that are higher than normal. This can result in noisy system operation and loss of air conditioning performance. (Air is not a good heat transfer medium, and higher pressures also mean higher condenser temperatures, which can also degrade system performance.) It can also cause the system's high pressure cut out switch to inhibit compressor clutch operation, and/or, depending on the circumstance, possibly cause damage to system components due to overpressure conditions.*

*The maximum acceptable amount of air contamination is generally considered to be no more than 2%.*

2. How can technicians determine if refrigerant contains too much air?

*The only way to determine the AMOUNT of air contained in refrigerant is to use a refrigerant identifier. But, to determine if a container of refrigerant has EXCESS air, the following approach can be used.*

- *The container must be kept at a stable temperature for several hours before taking the readings.*
- *Contamination can also be caused by mixed refrigerants which can produce readings similar to those in the charts on page 30, mimicking air contamination. In other words, the pressure/temperature method cannot identify whether the higher readings are being caused by air in the refrigerant, or if they are being caused due to refrigerant cross-contamination.*

#### **Pressure/ Temperature Method for Determining the Amount of Air Contained Within Refrigerant in a Container**

*To determine if a tank of recycled refrigerant contains an excessive amount of air, the tank must be stored at a temperature of at least 65° F for a period of 12 hours, protected from direct sunlight. It is also advisable not to*

*store tanks directly on the cement shop floor since the floor temperature can affect the tank temperature. Placing some form of insulation, such as a piece of wood between the tank and the floor will help stabilize the tank pressure. If these conditions have been met, a check for air may be performed as follows:*

- *Install a calibrated pressure gauge to the refrigerant container (some R/R machines have built-in ones).*



*This is a typical tank pressure gauge on a recovery/recycling machine. Its reading, with the ambient temperature reading and Tables 1 and 2 (on page 30), can be used to determine if excess air is in the refrigerant storage tank. If the pressure reading is too high, air must be purged from the tank until the gauge reading matches the proper one listed in the table. Still, a refrigerant identifier is the best tool to use to obtain a reading on the amount of air that might be in recycled refrigerant.*

#### NOTES:

---



---



---



---



---



---



---



- To obtain the refrigerant liquid temperature, measure the temperature of the lower one-half of the refrigerant container's outer surface (make sure the thermometer is in contact with the "liquid zone" of the tank). Using only the air temperature reading in the vicinity of the refrigerant container can result in incorrect information.
- Compare the pressure gauge and temperature readings with the limits found in Tables 1 and 2. Use the figures in Table 1 for CFC12, and the figures in Table 2 for HFC134a.
- If tank pressure is below the figure listed in the table, the refrigerant does not contain an excessive amount of air. If tank pressure is higher than that listed in the table for the ambient temperature, it is advisable to use a refrigerant identifier and confirm if the high pressure is due to excess air or cross-contamination. If it's determined to be excess air, **slowly** vent (purge) the air from the tank. Continue purging until tank pressure is below that shown in the table. As the purge process is performed, the container will cool and the tank pressure

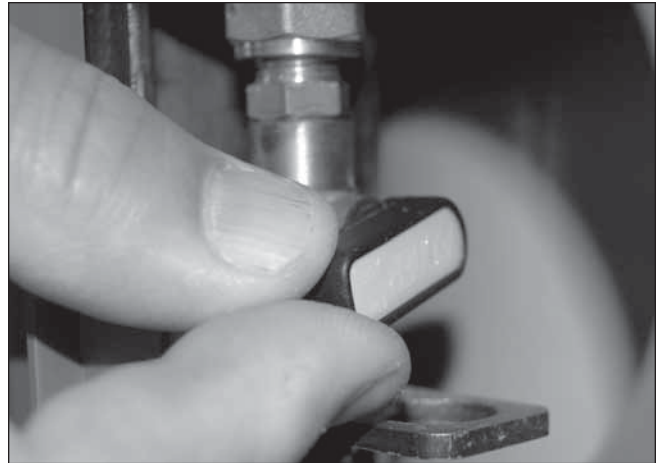

You can use the recovery/recycling/recharge machine's air purge valve to purge excess air from recycled refrigerant. Let the air out, and watch the pressure gauge on the machine's panel. When the gauge reading reaches the appropriate number in the table (based on the ambient temperature), close the purge valve. The recycled refrigerant now does not contain an excessive amount of air, and can be reused to recharge an A/C system.

**TABLE 1 - Maximum Allowable Container Pressure - Recycled CFC-12**

Temp ° F	PSI	Temp ° F	PSI	Temp ° F	PSI	Temp ° F	PSI	Temp ° F	PSI
65	74	75	87	85	102	95	118	105	136
66	75	76	88	86	103	96	120	106	138
67	76	77	90	87	105	97	122	107	140
68	78	78	92	88	107	98	124	108	142
69	79	79	94	89	108	99	125	109	144
70	80	80	96	90	110	100	127	110	146
71	82	81	98	91	111	101	129	111	148
72	83	82	99	92	113	102	130	112	150
73	84	83	100	93	115	103	132	113	152
74	86	84	101	94	116	104	134	114	154

**TABLE 2 - Maximum Allowable Container Pressure - Recycled HFC-134a**

Temp ° F	PSI	Temp ° F	PSI	Temp ° F	PSI	Temp ° F	PSI	Temp ° F	PSI
65	69	75	83	85	100	95	118	105	139
66	70	76	85	86	102	96	120	106	142
67	71	77	86	87	103	97	122	107	144
68	73	78	88	88	105	98	125	108	146
69	74	79	90	89	107	99	127	109	149
70	76	80	91	90	109	100	129	110	151
71	77	81	93	91	111	101	131	111	153
72	79	82	95	92	113	102	133	112	156
73	80	83	96	93	115	103	135	113	158
74	82	84	98	94	117	104	137	114	160



will decrease. Allow the temperature to stabilize then re-perform the check to confirm if there is still excess air remaining in the tank.

**Remember:** The information in the tables is only reliable if the tank has been kept at a stable temperature for several hours before the readings are taken, has been kept out of direct sunlight, contains some liquid refrigerant, and no refrigerant cross-contamination exists. It is also important that during the purge process, the tank does not become cold, since a cold tank of refrigerant will reflect an incorrect pressure reading. Also keep in mind that while pressures higher than those in the charts indicate contamination, they do not indicate the type of contamination (is it air, mixed refrigerants, or a combination of both?).

This procedure cannot be used to determine if a mobile A/C system has contamination from air or mixed refrigerant.

3. What can I do to address the problem of air in, and getting in, my refrigerant supply? How do I remove excess air from an A/C system?

Air can be introduced into the refrigerant supply when refrigerant is recovered if there are any leaks in the A/C system or the service hoses. Inspection of service equipment hoses and connections is important to assure that they are not a leak source.

The A/C system must be checked for leaks using approved leak detection equipment and methods. After performing refrigerant identification, the refrigerant must be recovered from the system using approved and properly maintained refrigerant recovery or recovery/recycling equipment. All system leaks (if any) must be repaired. After all refrigeration system service is completed, the system must be properly evacuated (to a deep vacuum) to ensure that all air is removed. Short cutting evacuation or failing to purge air from the recovered/recycled refrigerant are two of the most common causes for air to exist in refrigerant and A/C systems. Others are improperly operating or maintained recovery, recovery/recycling equipment, and vacuum pumps in need of oil changes and/or other maintenance.

Properly operating recycling equipment, used in accordance with its manufacturer's instructions, will remove excess air from refrigerant, ensure that the maximum allowable amount of air in recycled refrigerant is not exceeded, and provide recycled refrigerant that is ready for use.

### Mixed/Cross-contaminated Refrigerant

Mixed/cross-contaminated refrigerant is harmful for a number of different reasons.

If you mistakenly draw mixed refrigerant into your service equipment, not only could it possibly damage the equipment, but unless detected, you will contaminate every other vehicle that you use the equipment to service. Even a small amount of one refrigerant mixed with another can ruin the entire batch.

Mixed refrigerants can result in elevated system operating pressures. The raising of system operating pressures above normal can result in poor A/C performance and could also cause damage to system components.

Mixed refrigerants cannot be separated by recycling machines and are considered hazardous waste. They must be transported to an off-site facility for reclamation or destruction.

### Two More Issues Concerning Refrigerant and System Contamination

Just because a vehicle is equipped with a retrofit label and conversion fittings, it would not be wise to assume that the refrigerant in the system is a match to the fittings and the information on the label. There have also been cases of CFC-12 systems being directly charged with HFC-134a, with no labels, fittings, or any other type of indication that this was done. A vehicle could have passed through any number of hands before entering your shop, and there's no telling what could have happened along the way.

Also keep in mind that even approved chemicals, such as dye or lubricant, can become contaminants if they are in a system in excessive amounts.

### NOTES:

---



---



---



---



---



---



---



---



---



---





## Counterfeit Refrigerants

### R-What?

The potential for refrigerant cross-contamination has been a reality for many years. Initially the threat was viewed as being generated by a do-it-yourselfer, or maybe even another shop, introducing a can of the blend du jour or some illegal hydrocarbon cocktail into the A/C system before eventually bringing the car to an A/C specialist for repair.

But the threat is more complicated than that. Not only is there concern about what consumers or other shops introduce into the A/C system, professional shops must be vigilant about the supposedly virgin HFC-134a they are buying and using. Counterfeit refrigerant has also been around for a while, but the counterfeiters are growing in number and becoming more sophisticated.

DuPont Refrigerants issued a press release urging “members of the HVACR industry to increase their awareness of, and action against, counterfeit refrigerant activity.

“This problem is real and it is growing, and the impact can include significant injury and tragic loss of life,” said Greg Rubin, global business manager for DuPont Refrigerants. “Counterfeit refrigerants also have the potential for significant business impact, especially in emerging regions.”

All of the major refrigerant manufacturers have stepped up efforts to combat counterfeit activity, but it seems to be an uphill battle. Gus Rottoli, another industry expert, commented on that challenge noting, “We have recently seen cylinders that were copied almost exactly as the originals and were filled with refrigerants other than those on the label. Further, we have seen original, legitimate cylinders that were fraudulently obtained from the authorized cylinder manufacturers by a third party and filled with low quality or other refrigerant from what the label says. Just because the cylinder is (or looks) authentic, is no guarantee that the refrigerant it contains is pure or within specs. Buyers should indeed beware.”

Service providers should check each and every vehicle before doing anything to the A/C system. They

should also check every cylinder of refrigerant before installing it on a machine.

When the pace in your shop picks up, it might be tempting to skip that step of identifying the refrigerant you’re removing from the car. When times are tough and margins tight, you might also be tempted to go for a deal on refrigerant you find on the Internet or through a friend of a friend.

Remember that your reputation is on the line with every job you do. Take the time to identify the refrigerant you are working with and using, and buy your refrigerant through a known refrigerant manufacturer’s authorized distributor.

In the end, it may cost you more to take short-cuts versus taking the time to accurately identify what is in the vehicle and what is in the container.

Counterfeits can potentially:

- Prevent proper use of automated refrigerant R/R equipment.
- Cause internal corrosion of the A/C system, or may destroy hoses and other plastic/rubber components, which may allow escape of the refrigerant into the atmosphere, or into passenger cabin.
- Cause premature equipment failures.
- Void warranties on equipment.
- Cause explosions or fires, if flammable/explosive substances are used as the counterfeiting agents.
- Cause serious injury or death due to violent rupture of the contaminated system.

### Dangerous Counterfeit HFC-134a

In 2012 there were warnings about counterfeit HFC-134a refrigerant contaminated with significant quantities of R-40 (aka: methyl chloride or chloromethane). R-40 is extremely toxic, flammable and highly reactive when exposed to aluminum. In some cases R-40 may react with aluminum to form a third, highly unstable compound (trimethylaluminum or TMA) that ignites in contact with air.

This counterfeit HFC-134a mixed with R-40 and other refrigerants has apparently been purposely designed to mimic pure HFC-134a at a substantially



## Recovery and Disposal of Contaminated Refrigerant

Under federal law, contaminated refrigerant cannot be vented. Contaminated or unknown refrigerant must be removed from a system using dedicated recovery-only equipment, and properly disposed of.

There are currently two types of equipment that can be used to recover contaminated refrigerant:

- Recovery-only units offered by some equipment manufacturers that are specifically designed for this purpose;
- You may dedicate a CFG-12 or HFG-134a recovery unit specifically for the purpose of recovering contaminated refrigerant.

*Caution: If the refrigerant contains flammable substances, such as propane and butane, a fire or explosion could occur if the refrigerant is exposed to an ignition source within the equipment. Recovery equipment that has been certified for use with CFG-12 or HFG-134a is not approved for use with a flammable refrigerant and may become a safety hazard if used. Make sure you determine if features have been incorporated into your equipment to guard against these hazards.*

Also, refrigerant containing flammable substances may be considered hazardous, and you must follow any local, state or federal requirements governing the storage and disposal of ignitable materials (visit [www.ecarcenter.org](http://www.ecarcenter.org) for more information on specific disposal requirements).

reduced cost, the likely motivation of the counterfeiters. Refrigerant identifiers, certified to SAE J1771, are not designed to directly identify R-40. Some newer refrigerant identifiers, certified to SAE J2912, are designed to recognize small amounts of R-40 and classify it as an “Unknown” refrigerant.

Prior to issuing the warning, Neutronics Inc.’s Refrigerant Analysis Division had been engaged by the oceangoing shipping industry to assist with an HFG-134a refrigerant contamination problem involving R-40 that resulted in three deaths in three separate incidents. Since that time, Neutronics has been working with the Army, which positively identified HFG-134a contaminated with R-40 in Army depot supplies. Ground combat and tactical vehicles serviced in Afghanistan and Iraq were affected, and while the Army does not currently know the depth of contamination, it suspects that vehicles and reclaimed supplies may be contaminated.

It should be noted that these contaminated refrigerant systems can pose a major safety issue to those working on them. Currently the industry is working on, but has not determined, the best service procedures to be used. Contaminated systems can damage recovery and recycling equipment, and can result in the requirement to replace all vehicle refrigerant circuit components.

In April 2012, lab tests confirmed the presence of R-40 in a number of containers of recovered refrigerant in the U.S. With the confirmation from the military that infected vehicles have invaded our shores,

containment actions are of paramount importance. This problem has been seen in many parts of the world having much smaller mobile A/C fleets, so there is the potential for the same problem in the North American market.

While there is no reason to believe that this contamination is widespread in the U.S. market, its existence serves as one more reason service shops should remain vigilant and purchase their refrigerant from authorized distributors of their chosen refrigerant manufacturer.

### Steps to Avoid Counterfeit Refrigerants

- **KNOW YOUR SUPPLIER** Obtaining refrigerant from a trusted and well-known source that can provide traceability is a good practice to prevent contamination of equipment.
- **VERIFY REFRIGERANT IN CYLINDER BEFORE USING** Proper verification of refrigerant in service cylinders prior to use can ensure authenticity of the refrigerant. Checking refrigerant cylinders with a portable or integrated refrigerant analyzer is mandated by SAE service standards.
- **VERIFY REFRIGERANT IN SYSTEMS BEFORE REPAIRING/SERVICING** Proper verification of refrigerant in systems prior to repairing and/or servicing is imperative to safety. Testing refrigerant in systems prior to removing the charge also prevents possible contamination of your current (existing) supply.



Contaminated refrigerant must be sent off-site to an EPA certified refrigerant reclaimer for either reclamation or destruction. A list of EPA certified refrigerant reclaimers can be found on the EPA's web site at <https://www.epa.gov/section608/epa-certified-refrigerant-reclaimers>.

## Used Refrigerant from Non-mobile Sources

R12 and R134a are also used in residential and commercial refrigeration systems, such as refrigerators, water chillers and central cooling systems. Many different contaminants and acids may be present in refrigerant recovered from these systems. Automotive-type recovery/recycling equipment will not remove these contaminants.

Refrigerant which contains acids and other contaminants, as well as possibly mixed refrigerants, will cause serious problems if it is used in a mobile A/C system.

Refrigerant from non-mobile sources should not be used unless it has been purchased from a reclamation center which can certify that the refrigerant meets ARI 700 specifications.

## Purity of New HFC-134a

In 2006, both the SAE and the ARI issued more stringent standards concerning the purity of new HFC-134a, SAE J2776 and ARI 700-2006.



Make sure new HFC134a you intend to purchase meets the SAE J2776 and/or the ARI 700-2006 purity standard(s), and has a 1/2-inch Acme tank fitting.

To meet the ARI 700-2006 and SAE J2776 purity requirements, “volatile impurities” shall not exceed 40 parts per million (ppm). These impurities cannot be identified in the field, and the purity information is not normally part of the refrigerant’s Material Safety Data Sheet (MSDS). These impurities have been identified to potentially result in A/C system problems and health issues.

Refrigerant meeting SAE J2776 will have a label on the carton and container stating: “Meets SAE J2776 purity standard.” Containers will have 1/2-inch Acme fittings that will attach to the automotive service equipment. Refrigerant containers not having this fitting may not meet the SAE J2776 purity requirements.

### **Standard AHRI 700: Specification for Fluorocarbon Refrigerants**

**1.1 Purpose.** The purpose of this standard is to establish purity specifications, to verify composition, and to specify the associated methods of testing for acceptability of fluorocarbon refrigerants regardless of source (new, reclaimed and/or repackaged) for use in new and existing refrigeration and air conditioning products within the scope of AHRI.

**1.1.1 Intent.** This standard is intended for the guidance of the industry including manufacturers, reclaimers, repackagers, distributors, installers, servicemen, contractors and users of fluorocarbon refrigerants.

**1.1.2 Review and Amendment.** This standard is subject to review and amendment as technology advances or as additional data becomes available. This data can be submitted to AHRI for review.

### **Section 2. Scope**

**2.1 Scope.** This standard specifies acceptable levels of contaminants (purity requirements) for fluorocarbon refrigerants regardless of source and lists acceptable test methods.

## NOTES:

---

---

---

---

---

---

---

---





Empty refrigerant cylinders should be marked "Empty" before disposal.

## Recovering Refrigerant from Disposable Cylinders

Before they are discarded, disposable refrigerant cylinders should be connected to recovery equipment and brought to a vacuum. This will ensure that all refrigerant has been removed. The cylinder should then be marked "Empty." (Note: Some disposal facilities will not accept these cylinders unless some type of visual assurance exists that the cylinder is completely empty (such as a hole drilled in the cylinder.)

### **Standard J2296: Retest of Refrigerant Container**

*Issuing Committee: SAE International Interior Climate Control Fluids Committee*

This Standard defines a procedure to inspect a refrigerant cylinder used in equipment servicing mobile air conditioning (A/C) systems. This includes the pressure cylinder used for refrigerant recovery/recycling and charging equipment.



Before they are discarded, disposable refrigerant cylinders should be connected to recovery equipment and brought to a vacuum. This will ensure that all refrigerant has been removed.

## Field Coupling of Flexible Hose Assemblies

SAE J2064 is an engineering standard for joint integrity of hose couplings. This standard is important because it covers refrigerant hoses you install or repair. Improperly coupled hose assemblies are a reliability problem and result in loss of refrigerant. With smaller refrigerant charges, all the seals, joints and fittings have to be designed to leak far less. In today's small capacity systems, just a few ounces lost is enough to affect performance. And now, the systems are getting even tighter.

A MACS survey showed that half of the replacement hose assemblies are field coupled instead of installing new replacement assemblies. And because some of those shops make hose assemblies for other shops, they have a multiplier effect.

The following are some suggestions that will probably help you do a better job.

### NOTES:

---



---



---



---

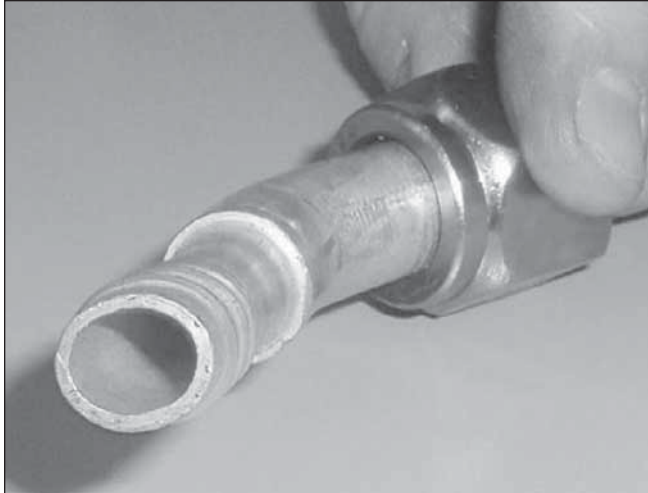

*Incorrect tube and hose combination causing tube to seriously deform.*



*Assembly crimped, rotated and re-crimped.*

## Practical Matters

Typical problems with the field-coupled hoses are damage to the coupling and incorrect crimping.

To assure the best field coupled hose and minimize refrigerant leakage, follow the hose coupling procedures for tube and hose fit and coupling requirements as outlined by the supplier.

Make sure to maintain your crimper and always use the proper dies for the particular job. Make sure that the fittings and hoses are a within-tolerance fit, and that the crimp meets the dimensions specified.

Do you just cut off the needed length of bulk hose, insert the fittings and turn the crimper's forcing screw until the joint seems "tight enough?" If so, what you're doing might be producing a coupling that will leak.

A major issue is the hose, which has greater size tolerances than the metal fittings. There are cases where the wrong-size fitting has been inserted - so loose that if you inverted the hose, the fitting might drop off. We also know of shops that believe "one crimper fits all" and use a hydraulic hose crimper on an A/C hose. It may produce a tight crimp, but it's been known to crack the hose's barrier lining.

The conscientious shop can do a great job when it comes to the field-assembly and repair of A/C system hoses.

## Measure Twice, Crimp Once

Is your bulk A/C hose a quality brand and do you have a hose cutter that produces a neat end?

Lube the hose end with mineral oil and insert the fitting. Although it won't be a difficult force fit, it shouldn't be drop-off loose either, even with the lubrication. The hose end should be visible in the small inspection hole on the side or end of the ferrule. If it isn't visible, it isn't fully inserted, and you could get a poor crimp.

## Appearance Counts

Inspect the crimp for a good visual appearance. It should be uniform and the fitting itself should not be deformed. Oblong, out-of-round or irregular crimps usually indicate worn die carriers or a mismatch of the two dies.

If the correct hose is used with the correct fittings, and the assembly operation is performed properly, you should be able to build and repair hose assemblies that meet the requirements for reduced leakage.

## Replacement Refrigerants and Retrofitting Mobile A/C Systems

Retrofitting CFC-12 systems to use an alternate refrigerant is permitted, provided that correct procedures are followed.

EPA regulations require that CFC-12 systems undergoing retrofit must have ALL of the CFC-12 recovered, appropriate conversion fittings must be installed on all of the original CFC-12 service ports, and a new A/C system information label must be affixed to the vehicle. The retrofit label must include the following information: the name and address of the technician and the company performing the retrofit; the date of the retrofit; the trade name, and charge amount of the refrigerant installed; and the type, manufacturer and amount of lubricant used. A high-pressure compressor cut-off switch must be installed IF the system does not already have one AND it contains a high-pressure refrigerant relief device. In addition, depending on the refrigerant being used, the installation of barrier hoses on systems that do not already have them may be required.

When retrofitting, the use of an alternate refrigerant not approved by the system manufacturer could result in damage to A/C system components. All mobile A/C system manufacturers encourage the continued use of CFC-12 in systems originally designed to use it.



Retrofit requirements and recommendations may include the installation of new o-rings and/or seals, new desiccant, a different lubricant, replacement of refrigerant controls, increased condenser capacity and other modifications. Not following OEM recommendation may result in system damage, loss of performance and could also affect component warranties. Additional information on retrofits can be found at the following link: <https://www.epa.gov/mvac/choosing-and-using-retrofit-refrigerant-cfc-12-mvac>.

### What About Retrofitting HFC-134a Systems?

HFC-134a systems are designed and tested only for use with HFC-134a and PAG or POE lubricant. There is no published information or industry-recognized tests to establish system cooling performance, system reliability, material compatibility or the potential for chemical damage to the system's lubricant, seals and hoses should a substitute refrigerant be installed in an HFC-134a system.

The new alternative refrigerants, HFC-152a, R-744 (CO<sub>2</sub>) and HFO-1234yf, are only approved by EPA for use in new

vehicles. A system designed to use HFC-134a cannot be retrofitted to use any of these refrigerants.

### A Word on Flammable Refrigerants

Replacement refrigerants which are or can become flammable have been sold for use in mobile A/C systems. CFC-12 and HFC-134a A/C systems are not designed to use flammable refrigerants, and using a flammable refrigerant as a replacement for CFC-12 is prohibited by federal law. EPA has explicitly listed any flammable substitute, besides HFC-152a and HFO-1234yf, as unacceptable under SNAP. Caution should be taken before working on any system suspected of containing flammable refrigerant; some electronic leak detectors could become an ignition source if being used to find leaks in a system containing flammable refrigerant; components inside many recovery/recycling machines can also serve as a possible ignition source if the equipment is being used to recover flammable refrigerant. Either of these situations could result in a fire or explosion.

Connection and disconnection of service equipment often results in the release of a small amount of refrigerant at the service ports. If the refrigerant released in these circumstances is flammable, and there is a source of ignition nearby, a fire or explosion could occur.

**WARNING: REMOVAL AND HANDLING OF FLAMMABLE REFRIGERANTS MAY BE DANGEROUS**

### The U.S. EPA's Significant New Alternatives Policy (SNAP)

Under the Significant New Alternatives Policy (SNAP), in addition to HFC-134a, the EPA has accepted other alternate refrigerants. Refer to Tables 3 through 6 on the following pages for additional information from EPA on these alternatives.

<p><b>CAUTION</b></p> <p>R-134a REFRIGERANT UNDER HIGH PRESSURE</p> <p>SYSTEM TO BE SERVICED BY QUALIFIED PERSONNEL ONLY. IMPROPER SERVICE METHODS MAY CAUSE PERSONAL INJURY.</p> <p><small>PIN 59979</small></p>	<p><b>NOTICE: RETROFITTED TO R-134a</b></p> <p>RETROFIT PROCEDURE PERFORMED TO SAE J1661</p> <p>USE ONLY R-134a REFRIGERANT AND SYNTHETIC OIL # _____ OR EQUIVALENT, OR A/C SYSTEM WILL BE DAMAGED</p> <p>DATE _____</p> <p>RETROFITTER NAME _____</p> <p>ADDRESS _____</p> <p>CITY / STATE _____</p> <p>REFRIGERANT CHARGE / AMOUNT _____</p> <p>LUBRICATION / TYPE _____ AMOUNT _____</p> <p>AUXILIARY LABEL LOCATION _____</p>
---	---



Even though a CFC-12 system may be equipped with a retrofit label and conversion fittings, that doesn't provide "proof" of the type of refrigerant that may be in the system, or its purity. The only way to know for sure is to connect a refrigerant identifier to the system and take a reading.

NOTES:

---



---



---



---



---



---





**TABLE 3 - Substitutes in MVAC: Passenger Air Conditioning in Light-Duty, Medium-Duty, Heavy Duty and Off-Road Vehicles**

**NOTE: All substitutes in this sector are acceptable, subject to use conditions, for CFC-12 (Class I ODS) in MVACs.\* See SNAP Regulations for more information.**

Substitutes are reviewed on the basis of environmental and health risks, including factors such as ozone depletion potential, global warming potential, toxicity, flammability, and exposure potential. Lists of acceptable and unacceptable substitutes are updated several times each year. The list of substitutes is shown below. **Note: SNAP-related information published in the Federal Register takes precedence over all information on this page.**

Substitute	Trade Name	Retrofit/ New	ODP	GWP	ASHRAE Designation (Safety Classif.)	Snap Listing Date	Listing Status
Evaporative Cooling		N	0	N/A	N/A	March 18, 1994	<b>Acceptable</b>
Free Zone (HCFC Blend Delta)	Free Zone / FB-276	R/N	0.013	1,592	A1	May 22, 1996; July 20, 2015	<b>Unacceptable</b> as of MY2017. Detailed conditions apply - see rule.
Freeze 12	Freeze 12	R/N	0.013	1,606	A1	October 16, 1996; July 20, 2015	<b>Unacceptable</b> as of MY2017. Detailed conditions apply - see rule.
GHG-HP (HCFC Blend Lambda)	GHG-HP	R/N	0.056	1,893	A1	October 16, 1996; July 20, 2015	<b>Unacceptable</b> as of MY2017. Detailed conditions apply - see rule.
GHG-X5	GHG-X5	R/N	0.032	2,377	A1	June 3, 1997; July 20, 2015	<b>Unacceptable</b> as of MY2017. Detailed conditions apply - see notice.
HFC-134a	134a	R/N	0	1,430	A1	March 18, 1994; July 20, 2015	<b>Unacceptable</b> as of Model Year (MY) 2021, except where allowed under a narrowed use limit through MY2025. Acceptable, subject to narrowed use limits, for vehicles exported to countries with insufficient servicing infrastructure to support other alternatives, for MY 2021 through MY2025. Unacceptable for all newly manufactured vehicles as of MY 2026. Detailed conditions apply - see rule.
HFC-152a <sup>1</sup>		N	0	124	A2	June 12, 2008	<b>Acceptable with Use Conditions:</b> See rule for detailed conditions.
HFO-1234yf <sup>2</sup>		N	0	4	A2L	March 29, 2011; December 1, 2016	<b>Acceptable with Use Conditions:</b> For use in newly manufactured passenger cars, light-duty trucks, medium-duty passenger vehicles, heavy-duty pickup trucks, and complete heavy-duty vans; see rules for detailed conditions.
Ikon A	Ikon-12, Blend Zeta	R/N	0	N/A	A1	May 22, 1996	<b>Acceptable with Use Conditions:</b> See rule for detailed conditions.
R-401C		R/N	0	933	A1	June 13, 1995	<b>Acceptable</b>
R-406A	GHG	R/N	0.057	1,900	A2	October 16, 1996; July 20, 2015	<b>Unacceptable</b> as of MY2017. Detailed conditions apply - see rule.
R-414A	GHG-X4, HCFC Blend XI, Autofrost, Chill-it	R	0.045	1,478	A1	October 16, 1996; July 20, 2015	<b>Unacceptable</b> as of MY2017. Detailed conditions apply - see rule.

Key: R= Retrofit Uses, N= New Uses

\* Refrigerated cargo areas, buses, and passenger trains using HCFC22 are not included in the definitions of "motor vehicle air-conditioners" or "motor vehicle-like air-conditioners" under EPA regulations for servicing of motor vehicle air conditioners.

1 See use conditions for HFC-152a at 73 FR 33304.

2 See use conditions for HFO-1234yf at 76 FR 17488.

3 See use conditions for R-744 (Carbon Dioxide, CO<sub>2</sub>).



Substitute	Trade Name	Retrofit/ New	ODP	GWP	ASHRAE Designation	Snap Listing Date	Listing Status
R-414B	Hot Shot, Kar Kool	R/N	0.098	3,337	A1	October 16, 1996; July 20, 2015	<b>Unacceptable</b> as of MY 2017. Detailed conditions apply - see rule.
R-416A	FRIGFR-12, HCFC Blend Beta	R/N	0.009	1,081	A1	June 13, 1995; July 20, 2015	<b>Unacceptable</b> as of MY 2017. Detailed conditions apply - see rule.
R-426A	FS-24	R/N	0	1,510	A1	September 28, 2006; July 20, 2015	<b>Unacceptable</b> as of MY 2017. Detailed conditions apply - see notice.
R-744 (Carbon Dioxide, CO <sub>2</sub> ) <sup>3</sup>		N	0	1	A1	June 6, 2012	<b>Acceptable with Use Conditions:</b> See rule for detailed conditions.
FS-24 (2002 formulation)		R/N	0	1,510	A1	December 20, 2002	<b>Acceptable with Use Conditions:</b> See notice for detailed conditions.
Small auxiliary power units that include an engine, electrical alternator, water pump, air conditioning compressor and a heat exchanger used in tractor trailers in conjunction with passenger compartment climate control systems that already use an acceptable substitute refrigerant.		R/N	0	N/A	N/A	June 19, 2000	<b>Acceptable</b>
SP34E	SP34E	R/N	0	<1,470	A1	December 18, 2000; May 23, 2001; July 20, 2015	<b>Unacceptable</b> as of MY 2017. Detailed conditions apply - see notice; use of new fittings for small refrigerant cans required.
Stirling Cycle		N	0	N/A	N/A	March 18, 1994	<b>Acceptable</b>

**Table 4 - Unacceptable Substitute Refrigerants**

Alternatives are listed as unacceptable where other available, or potentially available, substitutes pose a lower overall risk to human health and the environment.

Substitute (Name Used in the Federal Register)	ODS Being Replaced	End-uses	Reason
All flammable refrigerants, including OZ-12® (Hydrocarbon Blend A), HC-12a® (Hydrocarbon Blend B), and Duracool 12a except HFC-152a and HFO-1234yf in new MVACs	CFC-12	Motor vehicle air conditioning, retrofit and new	Lack of adequate assessment that characterizes incremental flammability risk
OZ-12® (Hydrocarbon Blend A), HC-12a® (Hydrocarbon Blend B), and Duracool 12a	CFC-12	All end-uses other than industrial process refrigeration, retrofit and new	Lack of adequate assessment that characterizes incremental flammability risk
R-141b	CFC-11	centrifugal chillers, new	High ODP; other substitutes with lower overall risk have been identified
R-176 (contains CFC-12, HCFC-22, and HCFC-142b. It is a different product from FB-276, typically sold under the name "Free Zone.")	CFC-12	All end-uses, retrofit and new	Contains CFC-12
R-403B	R-502	All end-uses, retrofit and new	Contains a perfluorocarbon that exhibits extremely high GWP*
R-405A	CFC-12	All end-uses, retrofit and new	Contains a perfluorocarbon that exhibits extremely high GWP*
MT-31	all CFCs and HCFCs	All end-uses, retrofit and new	Toxicity of a constituent
Hexafluoropropylene (HFP) and blends containing it	all CFCs and HCFCs	All end-uses, retrofit and new	HFP is toxic
NARM-22	HCFC-22	All end-uses, retrofit and new	Contains HCFC-22
Self-Chilling Cans using HFC-134a or HFC-152a	CFC-12, HCFC-22, R-502	Household Refrigeration, Transport Refrigeration, Vending Machines, Cold Storage Warehouses and Retail Food Refrigeration; retrofit and new.	Unacceptably high greenhouse gas emissions from direct release of refrigerant to the atmosphere

\* See this EPA URL for more detailed information: <https://www.epa.gov/snap/unacceptable-substitute-refrigerant>



**Table 5 - Unique Fittings for MVAC Refrigerants**

A unique set of fittings is required for each and every refrigerant approved for use in motor vehicle air conditioning (MVAC) systems under EPA's Significant New Alternatives Policy (SNAP). These fittings are attachment points on the car itself, on all recovery and recycling equipment, on large refrigerant containers, and taps on small cans of refrigerant and other charging equipment.

REFRIGERANT <i>(same list repeats next page)</i>	HIGH SIDE SERVICE PORT			LOW SIDE SERVICE PORT		
	Diameter (inches)	Pitch (threads/inch)	Thread Direction	Diameter (inches)	Pitch (threads/inch)	Thread Direction
OFC-12 (pre-1987)	7/16	20	Right	7/16	20	Right
OFC-12 (post-1987)	6/16	24	Right	7/16	20	Right
HFC-134a	Quick connect			Quick connect		
Freeze 12	7/16	14	Left	8/16	18	Right
Free Zone / HCFC Blend Delta	8/16	13	Right	9/16	18	Right
R-414B/HCFC Blend Omicron/Hot Shot	10/16	18	Left	10/16	18	Right
R-414A/GHG X4/ HCFC Blend Xi/ McCool Chill It	.305	32	Right	.368	26	Right
	6/16	24	Left	7/16	20	Left
GHG X5/Autofrost X5	8/16	20	Left	9/16	18	Left
R-406A/GHG 12/ GHG X3/McCool	.305	32	Left	.368	26	Left
R-416A/FRIGC FR-12/HCFC Blend Beta	Quick connect, different from HFC-134a			Quick connect, different from HFC-134a		
SP34E	7/16	14	Right	8/16	18	Left
R-426A (RS-24, new formulation)	Quick connect, different from HFC-134a and FRIGC FR-12			Quick connect, different from HFC-134a and FRIGC FR-12		
R-420A	0.5625 (9/16)	18	Right	0.5625 (9/16)	18	Left
HFO-1234yf	Outside diameter 17 +0/-0.2mm			Outside diameter 14 +0/-0.2mm		
	Quick connect consistent with J639 (2011 version)			Quick connect consistent with J639 (2011 version)		
HFC-152a	Outside diameter 15 +0/-0.2mm +			Outside diameter 14.1 +0/-0.2mm +		
	Quick connect consistent with J639 (2011 version)			Quick connect consistent with J639 (2011 version)		
R-744 (CO <sub>2</sub> )	Outside diameter 18.1 +0/-0.2 mm +			Outside diameter 16.6 +0/-0.2 mm +		
	Quick connect consistent with J639 (2011 version)			Quick connect consistent with J639 (2011 version)		

*+Direct final rule published March 26, 2012 and effective May 21, 2012 will change this to a left-handed screw fitting with diameter 8/16 inches and Acme shaped threading with 16 threads per inch, consistent with SAE J 2844 (October 2011 edition).*





The unique set of fittings for each refrigerant prevents the accidental mixing of different refrigerants. This helps protect the purity of refrigerant in the MVAC system. An adapter may not be used to convert a fitting. This list includes all refrigerants listed under SNAP as acceptable, subject to use conditions, for MVACs of May 21, 2012 for which unique fittings have been established. This table does not include GHG-HP/ HCFC Blend Lambda or Ikon-12/ Ikon A/ Blend Zeta because unique fittings have not been developed or approved for those refrigerants.

REFRIGERANT <i>(same list repeats previous page)</i>	30-LB. CYLINDERS			SMALL CANS		
	Diameter (inches)	Pitch (threads/inch)	Thread Direction	Diameter (inches)	Pitch (threads/inch)	Thread Direction
OFC-12 (pre-1987)	7/16	20	Right	7/16	20	Right
OFC-12 (post-1987)	7/16	20	Right	7/16	20	Right
HFC-134a	8/16	16 Acme	Right	8/16	16 Acme	Right
Freeze 12	8/16	18	Right	6/16	24	Right
Free Zone / HCFC Blend Delta	9/16	18	Right	6/16	24	Left
R-414B/HCFC Blend Omicron/Hot Shot	10/16	18	Right	5/16	24	Right
R-414A/GHG-X4/ HCFC Blend Xi/ McCool Chill It	.368	26	Right	14mm	1.25mm spacing	Left
GHG-X5/Autofrost X5	9/16	18	Left	Not sold in small cans		
R-406A/GHG-12/ GHG-X3/McCool	.368	26	Left	8/16	20	Left
R-416A/FRIGC FR-12/HCFC Blend Beta	8/16	20	Left	7/16	20	Left
SP34E	8/16	18	Left	5/16	24	Left
R-426A (FS-24, new formulation)	Quick connect, different from HFC-134a and FRIGC FR-12			Quick connect, different from HFC-134a and FRIGC FR-12		
R-420A	0.5625 (9/16)	18	Left	0.5625 (9/16)	18	Right
HFO-1234yf	8/16	16 Acme	Left <sup>Λ</sup>	8/16	16 Acme	Left
	Consistent with SAE J2844 (Oct 2011 version)			Submitted, but as of 12/2017 not approved by the EPA		
HFC-152a	Not yet developed*			Not yet developed*		
R-744 (CO <sub>2</sub> )	20.955 +0/-0.127 mm and right-hand thread direction			Not yet developed; additional information must be submitted to EPA *		

\* These refrigerants have not been marketed yet; therefore, fittings have not been developed.

Λ This unique fitting applies to containers of HFO-1234yf for professional servicing only (77 FR 17344).

**Beginning on January 1, 2018, small cans of MVAC refrigerants (including R-134a and R-1234yf) are required to be manufactured with self-sealing valves. See EPA Snap Rules on page 52 for more information.**



**Table 6 - MVAC Refrigerant Label Colors**

Historically, EPA established specific label colors for each refrigerant as part of its SNAP approval. This table includes only those refrigerants for which EPA required use of a specific label color as part of the listing decision. This table does not include all MVAC refrigerants, such as those for which labeling was never developed. Also, the use conditions for HFC-152a, R-744 (CO<sub>2</sub>) and HFO-1234yf require compliance with SAE J639, which specifies the markings required on labels, but not unique label colors. These refrigerants are not included in the table below and must be labeled in accordance with SAE J639.

REFRIGERANT	BACKGROUND
CFC-12	White
HFC-134a	Sky Blue
Freeze 12	Yellow
Free Zone / FB-276	Light Green
Hot Shot	Medium Blue
GHG-X4	Red
R-406A	Black
GHG-X5	Orange
GHG-HP	Not developed yet*
Ikon-12 / Ikon A	Not developed yet*
FRIGOR-12	Grey
SP34E	Tan
RS 426A (RS-24, new formulation)	Gold
R420A	Dark Green (RMS #347)

\* These refrigerants have not been marketed yet; therefore, label colors have not been developed.

## **BEST SERVICE PRACTICES FOR HFO-1234yf SYSTEMS**

### **INTRODUCTION**

**Standard J2845: R-1234yf (HFO-1234yf) Technician Training for Service and Containment of Refrigerant Used in Mobile A/C Systems**

*Issuing Committee: SAE International Interior Climate Control Service Committee*

Technician training is required to ensure that recommended procedures are used for service and repair of mobile air conditioning (MAC) systems using R-1234yf. The technician shall be trained to recognize which refrigerant is being handled, how to handle it safely and be equipped with the essential information, proper equipment and tools, which are unique to each refrigerant. Training programs designed in accordance with this standard are not intended to ensure or assess the technical skills of technicians regarding the diagnosis and repair of motor vehicle air conditioners. Rather, the goal of such programs is to provide information to technicians about safely handling refrigerants.

### NOTES:

---



---



---



---



---



---



---



---



## HFO-1234yf: SPECIFIC SAFETY PROCEDURES

Besides following all of the GENERAL safety procedures, HFO-1234yf has additional SPECIFIC safety require-

ments. To work safely with this chemical, a technician must know and follow these procedures.

1. HFO-1234yf is classed by ASHRAE as **A2L – Mildly Flammable**. It can ignite under certain circumstances. Always follow these steps before working with this chemical:
  - A. Insure good ventilation in the work area and do not allow the refrigerant to pool in or under the vehicle, or in any low area such as a stairwell or pit. Keep car doors and windows open when charging the A/C system to prevent an accumulation of refrigerant in case of a major refrigerant leak.
  - B. Remove ALL sources of sparks, flame or high heat from the immediate work area. This may include non-A/C related equipment such as grinders, welders, dryers and similar equipment. Some common shop tools contain electric motors or switches which spark internally; move this equipment to a safer area. Remember also that a vehicle's ignition system can produce external sparks under some conditions – take great care to prevent arcing and accidental grounding of electrical circuits.
  - C. Use LED work lights to prevent the risk of a broken bulb in the work area.
  - D. Do not smoke or permit smoking anywhere in or near the work area.
  - E. Keep well-maintained fire extinguishers in the work area and know how to use them.
2. Avoid contact with liquid or gaseous refrigerant. Always wear personal protective equipment (PPE) during service, particularly goggles with side panels, and gloves (impermeable to refrigerant). Exposure of the skin to refrigerant may result in frostbite, in which case rub the affected area with lukewarm water. A physician shall be consulted immediately regarding the affected skin areas.
  - A. A physician shall be consulted immediately in the event of complaints following exposure to high refrigerant concentrations. Complaint symptoms may include: Increased breathing rate, breathlessness, headache, accelerated pulse, dizziness.
3. Do not store refrigerant tanks in low areas such as basements or stairwells and do not transport tanks without securing them.
4. If the vehicle uses hybrid or all-electric propulsion, follow the correct procedure to de-activate the high voltage electrical system before beginning repairs. Note that these de-activation procedures may require additional personal protective equipment.
5. Prevent accidental release and exposure to refrigerant — only connect service equipment when high-side pressures have decreased, usually after the engine and compressor have been off for three minutes or more.
6. Do not allow anyone under the vehicle while recharging the system. Unexpected refrigerant leakage or a sudden release of the pressure valve will pool refrigerant near the ground. Always maintain good ventilation in the work area.
7. HFO-1234yf may only be used in systems specifically designed for it. Do not use this refrigerant in older cars, and do not use different refrigerants in a car designed for HFO-1234yf.
8. Each machine or device used to service a system with HFO-1234yf must be designed and approved for use with a flammable gas. Do not attempt to use equipment designed for other refrigerants on this system.
9. Read the label on the vehicle and know the correct amount of refrigerant to return into the system after evacuation.
10. Order the correct repair parts. Evaporators for HFO-1234yf systems are not the same as those used with HFC 134a, and other system components may be different as well.
11. You are responsible for the work you perform. Do not put your customers at risk with faulty, incorrect or quick-fix repairs.





## UNIQUE PROPERTIES OF HFO-1234yf SYSTEMS

The refrigerant HFO-1234yf is similar to, but not the same as, HFC-134a.

HFO-1234yf has been listed under EPA's SNAP as acceptable, subject to use conditions, for use in new vehicles; the refrigerant was not listed as acceptable for retrofit. The use conditions for HFO-1234yf include compliance with SAE J639, and manufacturers must conduct Failure Mode and Effect Analysis (FMEA) as provided in SAE J1739. (Additional information may be found in 40 CFR 82, subpart G, appendix B.) The new system designs will include some new components and materials.

### Risks and Hazards

The primary difference between this refrigerant and HFC-134a is its flammability, and care must always be taken concerning this hazard. However, technicians work with and around a variety of flammable materials every day including fuels, lubricants, welding gases and other materials. Common sense and safe shop practices can greatly reduce any hazard from this gas.

To become flammable in an enclosed area (such as a vehicle's cabin), the mixture of air and refrigerant must contain between 6.5% and 12.3% of the chemical vapor. Additionally, the mixture then requires a significant amount of energy to ignite—in some laboratory tests a spark similar to a direct short at the battery did not ignite the mixture. Other tests showed that a typical static discharge will not have sufficient energy to ignite the refrigerant. It is difficult to ignite, but not impossible.

Because of its flammability, and the possibility of refrigerant build-up in the passenger area from a leaking evaporator, manufacturers are being very careful in their system design. The industry has agreed to use special stronger evaporators in these systems. These units provide increased protection against corrosion and bursting and are also more resistant to pinhole leakage.

The increased performance specifications for evaporators are explained in SAE Standard J2842. It requires all evaporators for HFO-1234yf systems, both original equipment and replacement, to have a permanent marking (label, stamp, or etching) indicating the refrigerant for which it was designed and that the evaporator design meets the requirements of SAE J2842. **(Note: Only new evaporators should be used in CO<sub>2</sub> systems, as well.)**

Also note that it is unsafe to attempt any shop repair on a leaking evaporator – it should always be replaced with a correct, new unit to maintain occupant safety.

The re-use of a salvage or used evaporator from another vehicle may be dangerous and is not recommended, although a refrigerant control device such as a thermal expansion valve (TXV) or block valve may be reused if it is serviceable.

As these systems are developed and refined by their manufacturers, other components may also change including hose materials and desiccants. Always be very careful to order correct replacement parts for these systems.

### SAFETY IS IMPORTANT

Read the Material Safety Data Sheet (MSDS) for HFO-1234yf. The MSDS gives details of how to handle problems, including accidental inhalation, spills and fires. MSDS and product safety sheets are available from many sources, including your refrigerant supplier or on the Internet.

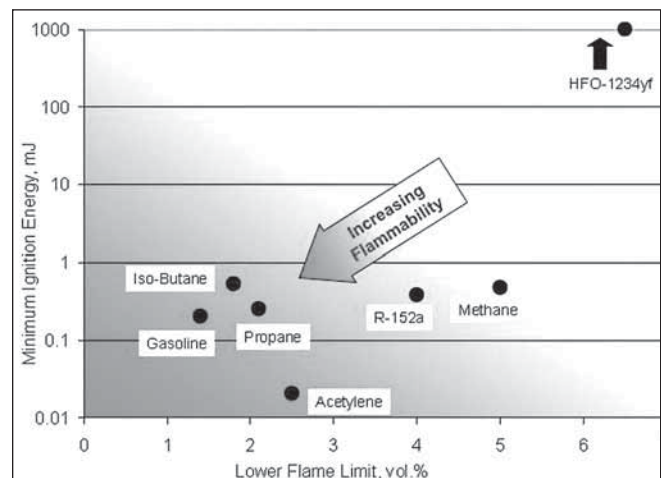

Comparison of energy required to ignite various chemical mixtures. (W Hill & SAE Int'l)

### Standard J2844: R-1234yf (HFO-1234yf) New Refrigerant Purity and Container Requirements for Use in Mobile Air Conditioning Systems

Issuing Committee: SAE International Interior Climate Control Fluids Committee

This SAE Standard applies to new refrigerant used in motor vehicle passenger air conditioning (A/C) systems designed to use R-1234yf, including belt and electrically driven compressors. Refrigerant for use in hermetically sealed, refrigerated cargo systems is not covered by this document.

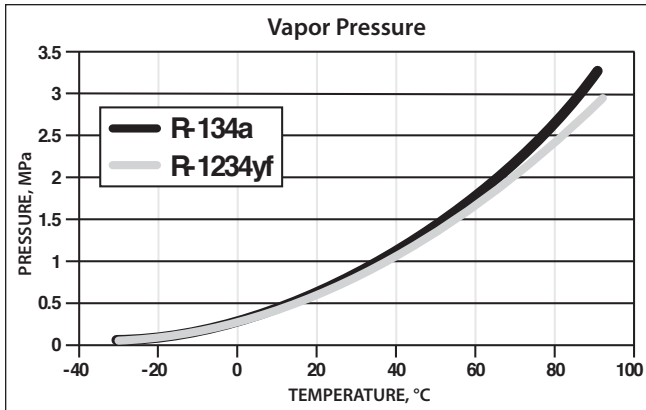

Vapor pressures for the two refrigerants are very similar except at extreme pressures.

### Hybrids and EVs

Many hybrid and electric vehicles use air conditioning compressors operated by high voltage. These types of vehicles usually incorporate a device to disconnect high voltage from the air conditioning system components. Before performing service on these systems, follow the vehicle manufacturer's recommended safety procedures. Not doing so could result in serious injury or death.



Example of a high voltage disconnect device on a hybrid vehicle. When performing service on any hybrid or electric vehicle, ALWAYS follow the vehicle manufacturer's recommended safety procedures.

### PURCHASE, STORAGE, AND TRANSPORT

All compressed gas in cylinders or portable tanks must be stored, handled and transported in accordance with the Compressed Gas Association Pamphlet P-1. Storage of multiple containers of refrigerant may be subject to local, state or federal rules or regulations.

Refrigerant cylinders must not be: exposed to direct sunlight or any other heat source; subject to mechanical stress resulting from dropping or throwing; stored in below ground areas or in front of cellar windows; filled in the workshop by workshop personnel; filled with another refrigerant; or transported without being securely stowed.

In general, do not expose any compressed gas cylinders (HFC-134a, HFO-1234yf, CO<sub>2</sub>, etc.) to temperatures in excess of 52 degrees C (125 degrees F), as this will result in cylinders becoming liquid full.

Rules from the U.S. Department of Transportation (DOT) already cover transporting flammable compressed gases. In general, they affect large shipments by truck, rail, ocean or air. However, shops and suppliers who transport more than a few refrigerant containers at a time should review the DOT rules to see if any changes will be needed.

### Similarities to HFC-134a

Although HFO-1234yf is not the same as HFC-134a, it is similar in many ways. As a refrigerant, it works at almost the same temperatures and pressures as HFC-134a.

Vapor pressures for the two refrigerants are very similar.

A technician will find that many present diagnostic procedures, such as measuring inlet and outlet temperatures at the condenser, will produce familiar results in these systems.

Industry tests showed that PAG oil is satisfactory for use with HFO-1234yf. PAG oil does not damage plastic or elastomeric components like the seals, connectors and o-rings used in an air conditioning system. The correct amount and type of oil will be determined by each vehicle or system manufacturer and may be shown on a label under the hood.

However, not all vehicles will use PAG oil. Many hybrids and other vehicles with electric compressors require a PCE or other oil. Always check for the label to learn the correct TYPE of oil and then use the correct AMOUNT of oil during repair.

**Note:** Proper operation of the mobile air conditioning and cooling systems in a hybrid vehicle is important not only for passenger comfort, but for the optimal operation of on-board computers and battery packs.



## TANKS, LABELS, AND FITTINGS

### Refrigerant Tanks

Tanks containing HFC-134a are light blue in color. Tanks and containers of HFO-1234yf are identified by information on printed labels and by the color and design of the container itself. To prevent confusion, HFO-1234yf containers will be white with a red stripe or band. The red is used to remind users that the product is flammable.



Aftermarket packaging of one brand of HFO-1234yf.

### Refrigerant Labels

#### CONTAINERS

The label and printed matter on the refrigerant container will identify the contents and provide limited emergency response information, including telephone numbers for use in an emergency. There are also directions for safe storage and handling of the chemical and other information. Note that the company may also display a trade name for the product and the names may be very different between companies. Always check that the tank contains HFO-1234yf and not another refrigerant.

#### VEHICLES

U.S. law requires every vehicle manufacturer to provide a standard label identifying the type and quantity of refrigerant used in the vehicle's air conditioning system and also the type of compressor lubricant (oil) used.

The label is always located in the engine compartment and is frequently on a crossmember near the radiator, or on the underside of the hood.



The refrigerant label is easy to find on the 2013 Cadillac XTS but you may have to look around on other vehicles.

The label for HFO-1234yf systems contains more information than those used on HFC-134a systems.



Label used on the 2013 Cadillac XTS, the first GM car to use the new refrigerant.

Note that, at the left of the label, the triangle and exclamation mark is the international symbol for a hazard. The center symbol indicates that the product is flammable, and the last one shows that special training is required to use this product. (The worker has a small medal or ribbon denoting completed training.)

Across the top are the symbols for “keep hands clear” and automatic fan(s) plus a warning that injury can occur – note the severed fingers! The last symbol directs technicians to consult “Information” in the service manual.

The snowflake is an international automotive symbol for air conditioning – it is used to identify both the refrigerant





erant and the type of lubricating oil (oil lamp symbol). Note that the amount of refrigerant may be indicated in kilograms, grams, ounces or pounds-and-ounces. Depending on your service equipment, you may have to perform mathematical conversions of the units before performing repairs and recharging.

**Fittings**

The law requires that the service fittings (“ports”) and connectors be unique for each refrigerant used. This requirement prevents contamination by assuring that service equipment for one refrigerant will not connect to a system using a different chemical. The rule applies to connections on supply tanks, service tools and the vehicle itself.

Most vehicle air conditioning systems have two service ports – HI pressure and LO pressure – while others have

only one. You may find the same thing on vehicles using HFO-1234yf refrigerant, but the service ports for these vehicles are different in size, shape and thread patterns from those on older systems.

The service ports on HFO-1234yf vehicles also still use the protective external caps, but the caps are new and use the new diameter and threads.

Your service and test equipment and the refrigerant tanks must have the correct connectors to match and connect to the vehicle. You will have to purchase new equipment (manifold gauges, recovery machines, etc.) to service HFO-1234yf refrigerant systems.

Do NOT attempt to connect older or incorrect equipment to these systems. Forcing a connector into place or using any type of adapter is not safe and is illegal.

**IDENTIFYING HFO-1234yf**

Technicians must always identify the refrigerant in a system before any other work is performed. It is critically important to keep refrigerants separated and to prevent contamination in both the vehicle and in your shop equipment. Mixing refrigerants, even accidentally, can lead to improper system pressures, system and component damage, diagnostic errors, and hazards to people and the environment.

Start by checking the refrigerant label to learn what should be in the system. Then connect the identifier to learn what is in the system. Remember that labels may be missing and owners may install adapters and other refrigerants.

A vehicle may also have been repaired with incorrect or impure refrigerant during mechanical or body shop repairs, or even by an owner trying to save some money. An identifier can prevent harmful chemicals from entering your shop equipment. You can also use the tool to double-check what is in a tank of refrigerant.

SAE J2843 requires that all recovery/recycle/recharge machines built for use with HFO-1234yf have either an integrated refrigerant identifier that complies with SAE J2927 or shall be capable of receiving input from a non-integrated, SAE J2912 compliant identifier, via an integrated USB port.

Identifiers are simple to use. Some detect certain refrigerants, while others are capable of sensing many gases. Naturally, you need a refrigerant identifier that is capable of detecting HFO-1234yf.



*Neutronics, Inc. refrigerant identifier*

If you already have a refrigerant identifier for other refrigerants, it is unlikely that it can be updated to also identify HFO-1234yf. You will need a new unit. When you purchase a refrigerant identifier (which is not part of a recovery/ recycle/ recharge machine) make certain it meets the specifications of SAE J2912. That document establishes criteria for the identifier’s level of sensing accuracy and other functions.

Keep in mind that even the best identifier may not be able to identify all of the possible combinations of chemicals that could be in an A/C system or storage tank.





Refrigerant identifiers are delicate electronic tools. They should be used carefully, stored properly and given periodic service to maintain their operation.

Connect the refrigerant identifier according to instructions that came with it. You may need to allow a bit of time for the unit to perform an internal calibration.

After the identifier samples the refrigerant, it will report the results. Some tools give only a Pass-Fail indication while others will report the percentages of

chemicals found. Identifiers that meet the SAE specification look for at least 98% concentration before reporting that the refrigerant is “pure.” If the identifier shows “Fail” or reports mixtures of refrigerants, the system must be evacuated into a “junk” tank, not the regular supply tanks of refrigerant.

### REMEMBER

Always identify the refrigerant in every system before beginning work.

### WARNING

If your refrigerant identifier shows an indication of “HC” or “hydrocarbon,” take extra caution.

These gases, (propane, butane, or others) are highly flammable and explosive. Take extreme care to contain these chemicals properly and recover them without leakage, using appropriate equipment.

## NOTES:

## FINDING LEAKS

### Electronic Leak Detectors

Make certain that your leak detector will recognize and react to HFO-1234yf.

Electronic leak detectors are sold under many brand names and use different methods to detect refrigerant. They require maintenance and careful use to protect

them from damage. Any detector you purchase should meet the performance requirements of SAE Standard J2913, which insures the tool (when set to its most sensitive mode) will be able to detect a leak as small as 0.15 ounces per year.



Electronic leak detectors are available from these and other manufacturers.



## Using Dyes

Before adding any dye to an A/C system, you must know what its manufacturer recommends. If a dye is permitted, you must use a product that is compatible with HFO-1234yf.



The leaking dye will glow under ultraviolet light. (Courtesy GPS Automotive Group)

Read the label and make sure the dye product you choose meets SAE specification J2297. By meeting this criteria, you are assured that the dye is compatible with the refrigerant and will not harm seals or lubricants.



**Standard J2299: Ultraviolet Leak Detection: Performance Requirements for Fluorescent Refrigerant Leak Detection Dye Injection Equipment for Aftermarket Service of Mobile Air Conditioning Systems**

Issuing Committee: SAE International Interior Climate Control Fluids Committee

This SAE Standard applies to fluorescent refrigerant leak detection dye injection equipment for use in ultraviolet leak detection when servicing mobile air conditioning systems.

Trace dyes, injectors, and detection lights are available individually or in kits from many suppliers.



## USING RECOVERY, RECYCLING, AND RECHARGING EQUIPMENT

### Basic Rules

1. Every tool or machine used to service or repair an HFO-1234yf system **MUST** be approved for use with that refrigerant.
2. Fittings and connectors for HFO-1234yf are different from any other refrigerant.

### Equipment Certification

Equipment for HFO-1234yf has been designed to safely handle flammable gas, and this equipment is **NOT** the same as equipment for other refrigerants.

For HFO-1234yf, recovery/recycling/recharge equipment must meet SAE Standard J2843 or J3030. Recovery-only units must meet SAE Standard J2851. Always use equipment that meets these standards.

### WHY IT'S IMPORTANT

Since HFO-1234yf A/C systems use a different refrigerant, some steps and processes for servicing the system are different from other refrigerants. In all cases, the refrigerant **MUST** be recovered.

### A/C System Recharge

Recovery and recharge equipment for HFO-1234yf represents a new generation of tools. The equipment is designed to prevent refrigerant leakage by checking the system under both vacuum and pressure.

Prior to operating the R/R/R machine, the technician will need to identify the vehicle or its refrigerant capacity by entering the data through the machine's keyboard.

**Standard J2888: R-1234yf Service Hose, Fittings and Couplers for Mobile Refrigerant Systems Service Equipment**

*Issuing Committee: SAE International Interior Climate Control Service Committee*

This SAE Standard covers fittings, couplers, and hoses intended for connecting service hoses from mobile air conditioning systems to service equipment such as charging, recovery and recycling equipment. This specification covers service hose fittings and couplers for MAC service equipment service hoses, per SAE J2843, SAE J3030, and SAE J2851, from mobile air conditioning systems to service equipment such as manifold gauges, vacuum pumps, and air conditioning charging, recovery and recycling equipment.

**Standard J2099: Standard of Purity for Recycled R-134a (HFC-134a) and R-1234yf (HFO-1234yf) for Use in Mobile Air Conditioning Systems**

This SAE Standard applies to: • recycled R-134a refrigerant, used in servicing of motor vehicle air conditioning (A/C) systems that were designed for use with R-12 and have been retrofitted for use with R-134a; • recycled R-134a refrigerant, used in servicing of motor vehicle air conditioning (A/C) systems that were designed for use with R-134a; • recycled R-1234yf refrigerant, used in servicing of motor vehicle air conditioning (A/C) systems that were designed for use with R-1234yf. Hermetically sealed, refrigerated cargo systems are not covered by this document.

Specifications for recycled R-1234yf :

- 3.1.1.1 High Boiling Residues (Lubricant) - 500 ppm by weight, by gravimetric method
- 3.1.1.2 Non-condensable Gases (Air) - 1.5% by volume, at 23.9 °C by gas chromatography
- 3.1.1.3 Moisture - 50 ppm by weight, by Karl Fischer method, or an equivalent method

**Refrigerant Recovery, Recycling, and Recharging Station**

**CAUTION:** Shall be operated by qualified personnel.

MODEL: AC1234-6 MFR: Bosch Automotive Service Solutions, LLC  
 VOLTS: 115V, 60 Hz  
 AMPS: 12.0

REFRIGERANT: R-1234yf only SERIAL NO.:

DESIGN PRESSURE:  
 High Side 275 PSIG  
 Low Side 167 PSIG

**Certified by UL LLC to meet SAE J2843 & UL1963**



**LISTED**  
 Recycling Equipment System 80S2



**Certified for high voltage electric compressors.**



**TO REDUCE RISK OF FIRE**

avoid the use of an extension cord, because the extension cord may overheat. If you must use an extension cord, the cord must be No. 14 AWG minimum and as short as possible.  
 Do not use this equipment in the vicinity of spilled or open containers of gasoline or other flammable substances.

The certification label shows the standards the unit meets and that the machine is for HFO-1234yf only (Courtesy Rbbinair).



Before delivering a full system charge, equipment used to recharge R-1234yf systems will first place the system under a minimum vacuum of -0.09 MPa gauge (26.9 in of mercury). The machine will then monitor the applied vacuum, and note if it decays. If the slope of the vacuum decay exceeds 51mm Hg/ min (2.0 in HG/ min) in five minutes, a leak is indicated and the machine will not permit the recharge process to continue. The technician shall locate and repair the leak(s) before again attempting to recharge the system.

If the system passes the vacuum decay check, the machine will instruct the user to turn the vehicle's HVAC blower motor on low (A/C off), with air distribution mode set to "floor," to run the blower for 1-2 minutes to clear any residual contamination, and to place an operating J2913 compliant leak detector's probe, with the unit set for maximum sensitivity, in the center of a floor ducts outlet.

The machine will require the user to verify that the leak detector is in place and the blower motor is on low. If "No," the machine will not allow user to continue.

If "Yes," the machine will charge 15% of the refrigerant system charge specified on the SAE J639 vehicle label, into both the high and low sides of the system. The user will be required to monitor the J2913 leak detector for 5 minutes for indication of a leak. The machine will require the user to indicate if a leak is detected or not.

If a leak is detected, the equipment will continue to hold for further external leak checking, and will lock out all operations except recovery and/ or re-evacuation.

If the vacuum decay and pressurized leak checks are passed, then the balance of the programmed amount will be charged.

Extra care should be taken to avoid significant overcharging of the refrigerant system.

### Critical Charges

HFO-1234yf systems use much less refrigerant than older systems, and are less tolerant of incorrect amounts. HFO-1234yf systems are designed to work best with a specific amount of refrigerant. More is NOT better, and a larger charge will not make the system cool better.

Although most recharging will be done with automatic equipment, mistakes are still possible and technicians must take every care to be accurate.

Undercharges can result in poor cooling and poor lubricant circulation in the compressor. Too much refrigerant or overcharging can cause high operating pressures, and poor cooling in the cabin.

**READ THE LABEL - HEED THE LABEL!**

Do not install an additional problem for your customer.

Always read the refrigerant capacity label on the vehicle and install that amount.



*You will need a new R/R machine just for HFO-1234yf. Some are available now and more will enter the market soon.*





## SYSTEM SERVICING PROCEDURES

Working with HFO-1234yf is not difficult, but it is different from many procedures you already know. At all times, the secrets to success are knowledge and safety.

### Remember the Basics:

- Learn and follow the safety procedures for storage and handling of HFO-1234yf. Anticipate problems and eliminate them.
- All refrigerant (except CO<sub>2</sub>) must be recovered. Refrigerant oil must also be recovered and disposed of according to all federal, state and local rules.
- Prevent contamination of refrigerants by using the proper equipment on each vehicle. Always identify refrigerants in a system before beginning any other work or connecting other equipment.
- Have the correct equipment before beginning. Any equipment connected to an HFO-1234yf system must be rated or approved for use with a flammable gas.

- Any component used to repair an HFO-1234yf air conditioning system **MUST** be rated or approved for use with that refrigerant. Substituting other components may present a hazard to vehicle occupants.
- For occupant safety, always replace failed evaporators with new units specifically designed for the task and complying with SAE J2842. Never attempt to repair a leaking HFO-1234yf evaporator or replace it with a used (salvage) unit.
- Always replace o-rings and seals with new pieces. Reusing old parts usually causes leaks.
- Take care to align the components when mating fittings and seals. Mount all components and lines securely to eliminate vibration and rubbing.
- Always tighten threaded fittings to the correct torque value given by the manufacturer.

## EPA SNAP RULES

On July 2, 2015, the final rule *Protection of Stratospheric Ozone: Change of Listing Status for Certain Substitutes under the Significant New Alternatives Policy Program* (<http://www.epa.gov/snap>) was signed by EPA Administrator Gina McCarthy. The rule, published in the Federal Register on July 20, had an effective date of August 19, 2015.

This rule makes the use of HFC-134a unacceptable in new automobiles and light trucks as of Model Year (MY) 2021, except where allowed under a narrowed use limit through MY 2025.

Of primary importance to the mobile A/C service industry, the published rule notes that “EPA did not propose and is not making any changes that would alter the ability to service existing motor vehicles designed to use HFC-134a.”

There are also several blend refrigerants that have been listed as acceptable or acceptable, subject to use conditions, since 1994, but that have never been developed for use in MAC or used in manufacture of new vehicles. This rule will change the status of these refrigerant blends to unacceptable as of MY 2017 for use in newly manufactured light-duty vehicles.

### 2016 EPA SNAP Update

On September 26, 2016, US EPA finalized rules that will reduce the projected growth and emissions of HFCs. They

affect Section 608 of the Clean Air Act, which extends the ODS (Ozone Depleting Substance) sales restriction to HFCs and other non-exempt substitutes, with the exception of small cans containing two pounds or less of (primarily) HFC-134a for servicing motor vehicle air conditioners. These small cans can continue to be sold without technician certification so long as the small cans have a self-sealing valve to reduce refrigerant leakage. It also applies to other non-ozone depleting substitutes such as R-1234yf, the new HFO that’s quickly becoming the replacement of choice for car and light truck manufacturers around the world due to its lower GWP (global warming potential).

The rule also lists HFO-1234yf as acceptable, subject to use conditions, for limited HD vehicle types, such as medium-duty passenger vehicles, HD pickup trucks and complete HD vans. It allows the use of yf in newly manufactured medium and heavy duty vehicles with a GVW of between 8,500 and 14,000 pounds (Classes 2b and 3) that are built with an air conditioning system designed to use R-1234yf.

### NOTES:



# REFRIGERANT RECYCLING AND SERVICE PROCEDURES FOR MOBILE AIR CONDITIONING TECHNICIANS

## THE HISTORICAL CONTEXT

Before the 1990s, it was common practice during the service of mobile air conditioning systems to just add refrigerant to leaking systems. It was also common practice to vent the entire refrigerant charge to the atmosphere if the refrigeration system required any type of service which involved opening the refrigerant circuit. These practices were acceptable because refrigerant was relatively inexpensive and thought to be environmentally benign.

But, knowing what we do today about the role of CFC-12 in the degradation of the earth's protective ozone layer, and the potential of global warming, venting refrigerants is irresponsible and is not permitted. Under the Clean Air Act, this activity is illegal; the EPA prohibits the venting of all mobile A/C refrigerants, except CO<sub>2</sub>.

To protect the ozone layer, the United States, and over 180 other nations ratified the 1987 Montreal Protocol on Substances which Deplete the Ozone Layer. This landmark international agreement is designed to control the production and consumption of certain chlorofluorocarbon and halon compounds.

Before the early 1990s, mobile air conditioning systems used CFC-12 refrigerant. With the advent of the Montreal Protocol, the industry changed to HFC-134a. In 1990, the U.S. Clean Air Act addressed the refrigerants used in mobile air conditioning systems.

CFC-12 has both an Ozone Depletion Potential (ODP) and Global Warming Potential (GWP). HFC-134a is not ozone-depleting, but is considered to have global warming potential. By late 1994, all new mobile air conditioning systems produced in the United States used HFC-134a.

## OZONE DEPLETION

Ozone is a pungent, slightly blue gas that absorbs certain wavelengths of the sun's radiation. Ozone is concentrated in a part of the atmosphere called the stratosphere. The stratosphere is located between 10 and 30 miles above the earth's surface.

The ozone layer acts as a shield against harmful solar Ultraviolet Beta (UVB) radiation. Ozone normally absorbs UVB. Decreasing the amount of stratospheric ozone results in higher levels of UVB reaching the earth's surface, and this increase can be harmful to humans, animals, plants, and the environment as a whole. It is estimated that for every percentage point that stratospheric ozone is reduced, exposure to ultraviolet radiation is increased by 1.5 to 2%.

Substances like chlorine, from synthetic chemicals called chlorofluorocarbons (CFCs), and bromine, from chemicals called halons, when released to the atmosphere, react in a way which reduces the amount of ozone in the stratosphere. CFCs were used as blowing agents in plastic foam products (cushioning, insulation and packaging), as refrigerants, as solvents, as sterilants, and in aerosol applications. Additionally, halons are used as fire extinguishing agents.

Growing awareness about the threat to the global environment, and the type and amount of refrigerant used



*CFCs were used for many different purposes, including refrigerants in mobile A/C systems prior to about 1992. Leaks and other releases allow them to enter the atmosphere.*

in mobile air conditioning systems, resulted in system design changes, and new service procedures and equipment to reduce system lifetime emissions.

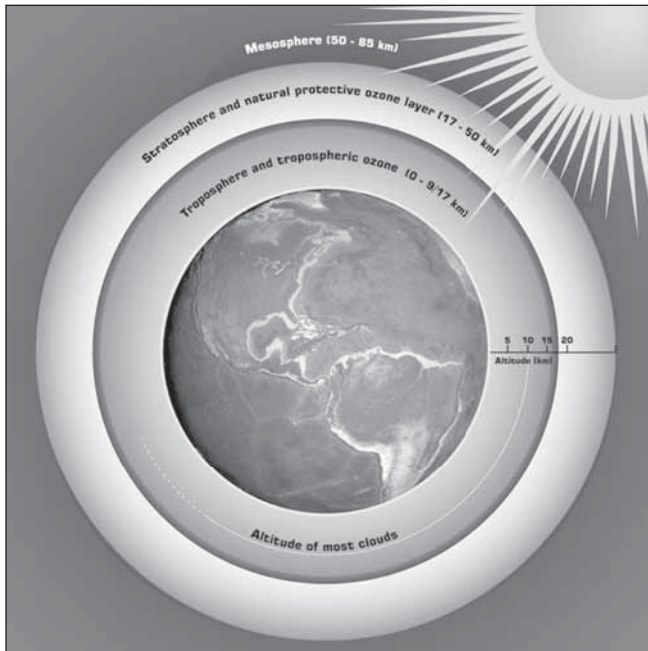

The ozone layer is located in the stratosphere about 10 to 30 miles (16 to 48 kilometers) above the earth's surface.

## CFCs and their Effect on Ozone

Possible depletion of the ozone layer from CFCs was first reported in 1974. Research indicated that chlorine released from CFCs could migrate to the stratosphere and destroy ozone molecules (Molina and Rowland, 1974).

Some CFCs have an atmospheric lifetime of more than 120 years (which means they do not break down in the lower atmosphere). As a result, they migrate slowly to the stratosphere where radiation from sunlight strikes them, releasing chlorine.

In the stratosphere, these chemicals absorb UV radiation, break apart, and react with ozone, taking away one oxygen atom and forming chlorine monoxide. Chlorine monoxide further breaks down ozone by pulling away a single oxygen atom, creating two oxygen molecules.

Once freed, the chlorine acts as a catalyst, repeatedly combining with, and breaking apart ozone molecules. It is believed that one CFC molecule can destroy as many as 100,000 ozone molecules.

Because of the long atmospheric lifetimes of CFCs, it will take many decades for the ozone layer to return to its former concentration. As CFC levels are reduced, the natural atmospheric process will rebuild the ozone level.

Until that time, increased UV levels can lead to a greater chance of overexposure to UV radiation and the health and environmental problems that result.

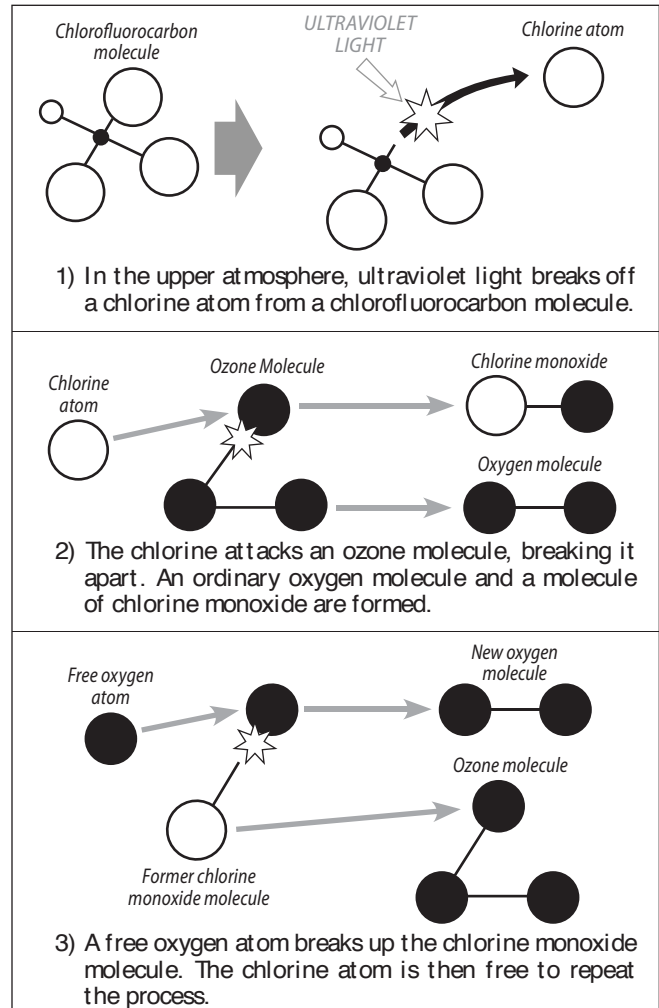

Chlorine atoms from CFCs break apart ozone molecules. This results in a reduction of stratospheric ozone.

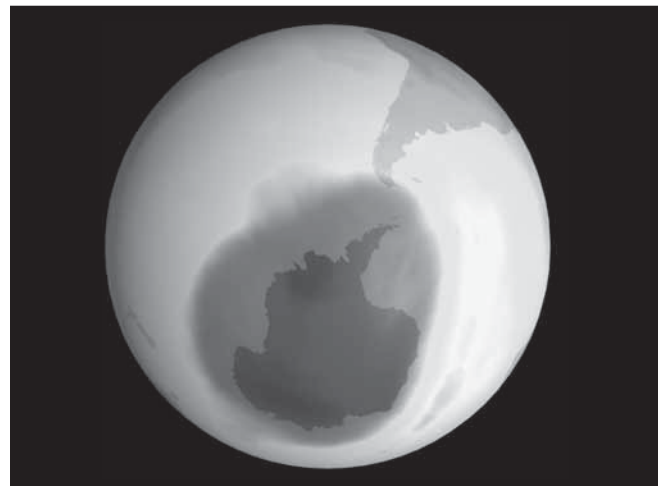

This shows how ozone depletion has resulted in an ozone hole located over the South Pole.





## Health and Environmental Effects

The Environmental Protection Agency's (EPA) assessment of the risks from ozone depletion has focused on the following issues:

- ◆ Increases in skin cancers
- ◆ Increases in cataracts
- ◆ Damage to the human immune system
- ◆ Damage to crops
- ◆ Damage to aquatic organisms

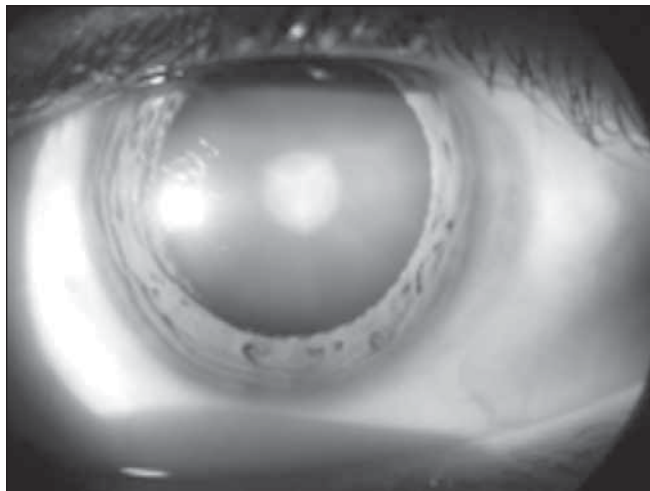

Increased levels of UV radiation can contribute to the formation of cataracts.

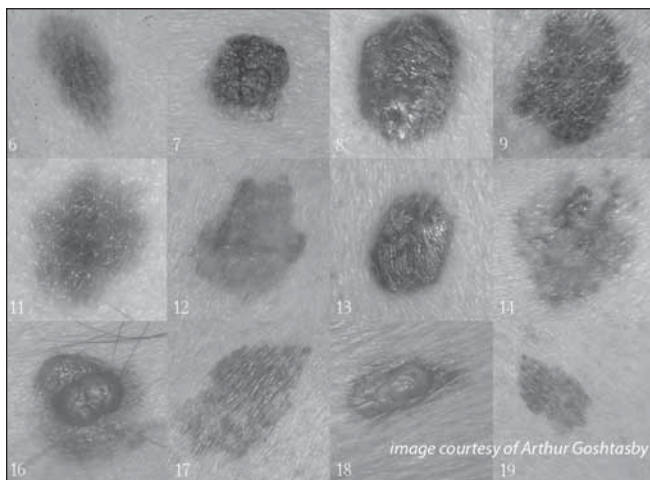

Types of skin cancer

## Other Impacts

**Degradation of Polymers** - Ozone depletion accelerates weathering (i.e. chalking, yellowing, and cracking) of plastics used in outdoor applications.

**Climate Change** - CFCs (and HFCs as well) are greenhouse gases which contribute to global warming and rising sea levels.

## Global Problem

Ozone protection is a global concern. CFCs and halons have been produced in the United States, and in other countries, and are still being used in nations around the world. Given their long atmospheric lifetimes, they have become widely dispersed over time. As a result, the release of these chemicals by one country can migrate up into the stratosphere, travel globally and adversely affect the health and welfare of other countries.

The United States, for example, was one of the largest producers and consumers of CFCs. Other nations also have been significant users.

Therefore, to protect the ozone layer, an international solution was critical.

## Montreal Protocol

Recognizing the global nature of the problem, on September 16, 1987, in Montreal, Canada, 24 nations and the European Economic Community (EEC) signed the Montreal Protocol on Substances which Deplete the Ozone Layer. The U.S. and other countries signing the Protocol agreed to phase out production of ozone-depleting substances. The 1990 Clean Air Act Amendments incorporated the Protocol's original phase-out date: the year 2000. In 1992, President George H. W. Bush pledged to halt almost all U.S. production of CFCs by the end of 1995.

## AMENDMENT TO ADDRESS HFCs UNDER THE MONTREAL PROTOCOL

On October 15, 2016, 197 countries adopted an amendment to phase down HFCs under the Montreal Protocol in Kigali, Rwanda. Under the amendment, countries committed to cut the production and consumption of HFCs by more than 80 percent over the next 30 years. The ambitious phase down schedule will avoid more than 80 billion metric tons of carbon dioxide equivalent emissions by 2050—avoiding up to 0.5° Celsius warming by the end of the century—while continuing to protect the ozone layer. The US and other developed countries will reduce HFC consumption beginning in 2019 and freeze consumption in 2024, with a small number of developing countries freezing consumption in 2028.

## NOTES:

---



---



---





## The Chemicals

Listed below are chemicals and their associated ODP (Ozone Depletion Potential) values as well as their GWP (Global Warming Potential) values. An ODP value is a measure of a chemical's relative ability to destroy ozone molecules in the stratosphere. A GWP is a measure of a chemical's relative ability to produce a global warming effect.

The higher the ODP value, the greater a chemical's potential to destroy ozone in the stratosphere. The higher the GWP value, the greater a chemical's influence on global warming.

### Fully-Halogenated Chlorofluorocarbons

	ODP	GWP	
CFC11	1.0	4,680	
CFC12	1.0	10,900	

### Comparison to HFC134a

	ODP	GWP	
HFC134a	0	1,430	

## Tax on CFC-12

On January 1 of each year, businesses with an inventory, or floor stock, of 400 pounds of CFC-12 or more, are required to report their inventory and pay the difference between the prior year tax rate per pound. Each year, the floor tax increases 45 cents on each pound of refrigerant in stock. (Refrigerant recycled on-site from mobile A/C systems is not taxable.)

The floor stock tax on ozone-depleting chemicals is due and payable without assessment or notice on or before June 30.

If a businesses' inventory is 399 pounds or less, no tax payment is required. If inventory is 400 pounds or more, tax is required on all of the refrigerant – the first 399 pounds is not exempted.

**Note: Consult your tax advisor for additional information.**

## CFC-12 Possession and Use

It is legal to store and use CFC-12 for servicing mobile A/C systems. However, only technicians certified under section 608 or 609 of the Clean Air Act may purchase it.

For more information on EPA regulations applicable to mobile A/C system service, visit [www.epa.gov/ozone/title6/609](http://www.epa.gov/ozone/title6/609), or call the EPA's Stratospheric Ozone Protection Hotline at 800-296-1996.

## Important Dates

**Jan. 1, 1992:** Since this date, containment and recycling of CFC-12 and HCFC refrigerants has been required.

**Nov. 15, 1992:** Since this date, sales of containers of CFCs under 20 pounds to anyone other than certified Section 609 technicians has been prohibited.

**Nov. 14, 1994:** Since this date, the sale of ozone-depleting refrigerants in any size container is restricted to certified technicians.

**July 1995:** Since this date, any CFC-12 mobile air conditioning system that is converted (retrofitted) to use an EPA accepted alternate refrigerant must have installed the appropriate unique service fittings and label listed for that refrigerant.

**Nov. 15, 1995:** Since this date Section 608 of the Clean Air Act (the Act) prohibits individuals from knowingly venting substitutes\* for CFC and HCFC refrigerants during the maintenance, service, repair and disposal of air conditioning and refrigeration equipment.

**January 1, 2018:** Starting on this date, the sale of ODS and substitute refrigerant is restricted to certified technicians.

*It must be noted that the above regulations apply no matter where a system is undergoing service, whether it be in a shop, or at an "off-site" location, such as a farm field, construction site, parking lot, etc. Approved recovery-only, or recovery/recycling equipment can, and must be used any time refrigerant must be removed from a system for any reason.*

**\* CO<sub>2</sub> is exempt from this venting prohibition.**

## NOTES:

---



---



---



---



---



**MVAC RECOVER, RECOVER/RECYCLE OR RECOVER/RECYCLE/RECHARGE  
EQUIPMENT CERTIFICATION FORM**

**1** \_\_\_\_\_  
NAME OF ESTABLISHMENT

\_\_\_\_\_  
STREET

\_\_\_\_\_  
CITY, STATE, ZIP CODE

\_\_\_\_\_  
TELEPHONE NUMBER

SEND THIS FORM TO THE EPA REGIONAL OFFICE LISTED UNDER YOUR STATE OR TERRITORY IN WHICH THE ESTABLISHMENT IS LOCATED.

**2** \_\_\_\_\_  
NAME OF EQUIPMENT MANUFACTURER & MODEL NUMBER

\_\_\_\_\_  
SERIAL NUMBER(S)                      YEAR

MAILING ADDRESSES CAN BE FOUND ON THE REVERSE SIDE OF THIS FORM.

**3** I certify that I have approved recover, recover/recycle, or recover/recycle/recharge equipment under Section 609 of the Clean Air Act. I certify that only properly trained and certified technicians operate the equipment and that the information given above is true and correct.

\_\_\_\_\_  
SIGNATURE OF OWNER/OPERATOR      DATE

\_\_\_\_\_  
NAME (PRINT)                                      TITLE

**MVAC RECOVER, RECOVER/RECYCLE OR RECOVER/RECYCLE/RECHARGE  
EQUIPMENT CERTIFICATION FORM INSTRUCTIONS**

Motor vehicle refrigerant recover, recover/recycle, or recover/recycle/recharge equipment must be acquired by January 1, 1992 and certified to EPA on or before January 1, 1993 under Section 609 of the Clean Air Act. To certify your equipment, please complete the above form according to the following instructions and mail to the appropriate EPA region based on where your establishment is located.

**1** Please provide the name, address, and telephone number of the establishment where the equipment is located.

**2** Please provide the name brand, model number, year and serial number(s) of the equipment acquired for use at the above establishment.

**3** The certification statement must be signed by the person who has acquired the equipment (the person may be the owner of the establishment or another responsible officer). The person who signs is certifying that they have acquired the equipment, that each individual authorized to use the equipment is properly trained and certified, and that the information provided is true and correct.



### **EPA REGIONAL OFFICES**

Send your form to the EPA office listed under the state or territory in which the establishment is located.

#### **Connecticut, Maine, Massachusetts, New Hampshire, Rhode Island, Vermont**

CAA section 609 Enforcement Contact, EPA Region 1; 5 Post Office Square, Suite 100, OES04-02, Boston, MA 02109-3912.

#### **New York, New Jersey, Puerto Rico, Virgin Islands**

CAA section 609 Enforcement Contact, EPA Region 2 (2DECA-AC); 290 Broadway, 21st Floor; New York, NY 10007-1866

#### **Delaware, District of Columbia, Maryland, Pennsylvania, Virginia, West Virginia**

CAA section 609 Enforcement Contact, EPA Region 3 – Wheeling Operations Office; Mail Code 3AP12, 303 Methodist Building, 11th and Chapline Streets, Wheeling, WV 26003

#### **Alabama, Florida, Georgia, Kentucky, Mississippi, North Carolina, South Carolina, Tennessee**

CAA section 609 Enforcement Contact, EPA Region 4 (APT-AE); Atlanta Federal Center; 61 Forsyth Street SW, Atlanta, GA 30303

#### **Illinois, Indiana, Michigan, Minnesota, Ohio, Wisconsin**

CAA section 609 Enforcement Contact, EPA Region 5 (AE17J); 77 West Jackson Boulevard, Chicago, IL 60604-3507

#### **Arkansas, Louisiana, New Mexico, Oklahoma, Texas**

CAA section 609 Enforcement Contact, EPA Region 6 (6EN-AA); 1445 Ross Avenue, Suite 1200, Dallas, TX 75202

#### **Iowa, Kansas, Missouri, Nebraska**

CAA section 609 Enforcement Contact, EPA Region 7; Mail Code APCO/ARTD; 11201 Renner Boulevard, Lenexa, KS 66219

#### **Colorado, Montana, North Dakota, South Dakota, Utah, Wyoming**

CAA section 609 Enforcement Contact, EPA Region 8; 1595 Wynkoop Street, Denver, CO 80202

#### **American Samoa, Arizona, California, Guam, Hawaii, Nevada**

CAA section 609 Enforcement Contact, EPA Region 9; Mail Code AIR-5, 75 Hawthorne Street, San Francisco, CA 94105

#### **Alaska, Idaho, Oregon, Washington**

CAA section 609 Enforcement Contact, EPA Region 10 (OAQ-107); 1200 Sixth Avenue, Seattle, WA 98101



**Air Conditioning & Heating Customer Questionnaire**

Customer Name \_\_\_\_\_ Date \_\_\_\_\_ Address \_\_\_\_\_  
 City \_\_\_\_\_ State \_\_\_\_\_ Zip \_\_\_\_\_ Home Phone \_\_\_\_\_ Cell Phone \_\_\_\_\_  
 Vehicle Year \_\_\_\_\_ Make \_\_\_\_\_ Model \_\_\_\_\_ Color \_\_\_\_\_  
 V.I.N. \_\_\_\_\_ License Plate Number \_\_\_\_\_  
 A/C System Type –      Manual                       Auto. Temp. Control                       Dual / Rear Auxiliary Unit

**PROBLEM / SYMPTOM**

<input type="checkbox"/> No A/C	<input type="checkbox"/> No Heat	<input type="checkbox"/> No Defrost	<input type="checkbox"/> Poor Cooling	<input type="checkbox"/> Poor Heating
<input type="checkbox"/> Improper Fan/Blower Operation	<input type="checkbox"/> Air From Wrong Outlet(s)	<input type="checkbox"/> No Temperature Control	<input type="checkbox"/> Noise Inside Car	<input type="checkbox"/> Noise Under Hood
<input type="checkbox"/> Interior Water Leak	<input type="checkbox"/> Engine Coolant Leak	<input type="checkbox"/> Warning Light(s) On	<input type="checkbox"/> Odor	<input type="checkbox"/> Other* (See Below)

**WHEN DOES THE PROBLEM OCCUR?**

<input type="checkbox"/> Always	<input type="checkbox"/> Intermittent	<input type="checkbox"/> When Hot	<input type="checkbox"/> When Cold	<input type="checkbox"/> At Start Up
<input type="checkbox"/> During Warm Up	<input type="checkbox"/> At Idle	<input type="checkbox"/> High Engine Speeds	<input type="checkbox"/> Driving Away From Stop	<input type="checkbox"/> At Road Speeds

Have there been any previous attempts to repair this problem?  No      Yes  
 If there were previous repair attempts, what was done? (What parts were installed, etc.)

\_\_\_\_\_

\_\_\_\_\_

Did previous repairs help the problem?  No      Some      A lot      At first, but not now.  
 Have repairs or service of any kind been recently performed to the vehicle?  No      Yes

If so, exactly what was done?  
 \_\_\_\_\_

\_\_\_\_\_

**\*FURTHER DESCRIPTION OF THE PROBLEM**

\_\_\_\_\_

\_\_\_\_\_





**A/C / Heating / Ventilation / Cooling System Checklist**

Vehicle Year \_\_\_\_\_ Make \_\_\_\_\_ Model \_\_\_\_\_ Engine \_\_\_\_\_  
 V.I.N. \_\_\_\_\_ System Type:  R-1234yf  R134a  R12  Retrofitted  Front  Rear  
 Customer Name \_\_\_\_\_ Date \_\_\_\_\_ Address \_\_\_\_\_  
 City \_\_\_\_\_ State \_\_\_\_\_ Zip \_\_\_\_\_ Home Phone \_\_\_\_\_ Cell Phone \_\_\_\_\_  
 Refrigerant I.D./Analysis: R-1234yf \_\_\_\_\_ % R-134a \_\_\_\_\_ % R-12 \_\_\_\_\_ % HC \_\_\_\_\_ % Air \_\_\_\_\_ %  
 Other \_\_\_\_\_ % Gauge Readings: High Side \_\_\_\_\_ psi Low Side \_\_\_\_\_ psi @ \_\_\_\_\_ RPM

COMPONENT	OK	REPAIR	COMPONENT	OK	REPAIR
<b>1. Belts</b>			<b>14. Electric Cooling Fans(s)</b>	<input type="checkbox"/>	<input type="checkbox"/>
Condition	<input type="checkbox"/>	<input type="checkbox"/>	Mounting	<input type="checkbox"/>	<input type="checkbox"/>
Tension	<input type="checkbox"/>	<input type="checkbox"/>	Operation	<input type="checkbox"/>	<input type="checkbox"/>
<b>2. Belt Tensioner</b>	<input type="checkbox"/>	<input type="checkbox"/>	Noise	<input type="checkbox"/>	<input type="checkbox"/>
<b>3. Pulleys/Idler Pulley</b>	<input type="checkbox"/>	<input type="checkbox"/>	Electrical Connections	<input type="checkbox"/>	<input type="checkbox"/>
Alignment/Spacing	<input type="checkbox"/>	<input type="checkbox"/>	<b>15. Fan Clutch</b>	<input type="checkbox"/>	<input type="checkbox"/>
<b>4. Compressor</b>	<input type="checkbox"/>	<input type="checkbox"/>	Operation	<input type="checkbox"/>	<input type="checkbox"/>
Leakage	<input type="checkbox"/>	<input type="checkbox"/>	Fluid Leakage	<input type="checkbox"/>	<input type="checkbox"/>
Mounting/Alignment	<input type="checkbox"/>	<input type="checkbox"/>	<b>16. Radiator</b>	<input type="checkbox"/>	<input type="checkbox"/>
Noise	<input type="checkbox"/>	<input type="checkbox"/>	Leakage	<input type="checkbox"/>	<input type="checkbox"/>
<b>5. Compressor Clutch</b>	<input type="checkbox"/>	<input type="checkbox"/>	Mounting	<input type="checkbox"/>	<input type="checkbox"/>
Air Gap	<input type="checkbox"/>	<input type="checkbox"/>	Cleanliness	<input type="checkbox"/>	<input type="checkbox"/>
Bearing	<input type="checkbox"/>	<input type="checkbox"/>	Hoses and Clamps	<input type="checkbox"/>	<input type="checkbox"/>
Field Coil	<input type="checkbox"/>	<input type="checkbox"/>	<b>17. Coolant Reservoir</b>	<input type="checkbox"/>	<input type="checkbox"/>
Electrical Connections	<input type="checkbox"/>	<input type="checkbox"/>	<b>18. Pressure Cap</b>	<input type="checkbox"/>	<input type="checkbox"/>
Surge Suppression Diode	<input type="checkbox"/>	<input type="checkbox"/>	<b>19. Thermostat</b>	<input type="checkbox"/>	<input type="checkbox"/>
<b>6. Condenser</b>	<input type="checkbox"/>	<input type="checkbox"/>	Correct Temperature	<input type="checkbox"/>	<input type="checkbox"/>
Leakage	<input type="checkbox"/>	<input type="checkbox"/>	<b>20. Coolant</b>	<input type="checkbox"/>	<input type="checkbox"/>
Mounting	<input type="checkbox"/>	<input type="checkbox"/>	Cleanliness/pH	<input type="checkbox"/>	<input type="checkbox"/>
Cleanliness	<input type="checkbox"/>	<input type="checkbox"/>	Test Results/Freeze Protection	<input type="checkbox"/>	<input type="checkbox"/>
<b>7. Receiver Drier/Accumulator</b>	<input type="checkbox"/>	<input type="checkbox"/>	<b>21. Heater Hoses and Clamps</b>	<input type="checkbox"/>	<input type="checkbox"/>
Mounting	<input type="checkbox"/>	<input type="checkbox"/>	<b>22. Heater Control Valve</b>	<input type="checkbox"/>	<input type="checkbox"/>
Fittings/Connections	<input type="checkbox"/>	<input type="checkbox"/>	<b>23. Evaporator</b>	<input type="checkbox"/>	<input type="checkbox"/>
<b>8. A/C Hoses and Lines</b>	<input type="checkbox"/>	<input type="checkbox"/>	Leakage	<input type="checkbox"/>	<input type="checkbox"/>
Leaks	<input type="checkbox"/>	<input type="checkbox"/>	Connections/Fittings	<input type="checkbox"/>	<input type="checkbox"/>
Fittings/Connections	<input type="checkbox"/>	<input type="checkbox"/>	Condensate Drain	<input type="checkbox"/>	<input type="checkbox"/>
Rub Through	<input type="checkbox"/>	<input type="checkbox"/>	Odor	<input type="checkbox"/>	<input type="checkbox"/>
Mounting	<input type="checkbox"/>	<input type="checkbox"/>	<b>24. Panel Outlet Temperature</b>	<input type="checkbox"/>	<input type="checkbox"/>
<b>9. Service Port Caps</b>	<input type="checkbox"/>	<input type="checkbox"/>	<b>25. Dash Controls/Switches</b>	<input type="checkbox"/>	<input type="checkbox"/>
<b>10. Expansion Valve</b>	<input type="checkbox"/>	<input type="checkbox"/>	Proper Air Routing	<input type="checkbox"/>	<input type="checkbox"/>
Leaks	<input type="checkbox"/>	<input type="checkbox"/>	Cable Operation	<input type="checkbox"/>	<input type="checkbox"/>
Sensing Bulb	<input type="checkbox"/>	<input type="checkbox"/>	<b>26. Blower Motor Operation</b>	<input type="checkbox"/>	<input type="checkbox"/>
Insulation	<input type="checkbox"/>	<input type="checkbox"/>	<b>27. A/C/Blower/Fan Relays</b>	<input type="checkbox"/>	<input type="checkbox"/>
<b>11. Orifice Tube</b>	<input type="checkbox"/>	<input type="checkbox"/>	<b>28. Underhood Switches/Controls/Sensors</b>	<input type="checkbox"/>	<input type="checkbox"/>
Fittings	<input type="checkbox"/>	<input type="checkbox"/>	Broken	<input type="checkbox"/>	<input type="checkbox"/>
Leaks	<input type="checkbox"/>	<input type="checkbox"/>	Electrical Connections	<input type="checkbox"/>	<input type="checkbox"/>
<b>12. Fan Shroud/Seals</b>	<input type="checkbox"/>	<input type="checkbox"/>	Operation	<input type="checkbox"/>	<input type="checkbox"/>
<b>13. Front Air Dam/Spoiler</b>	<input type="checkbox"/>	<input type="checkbox"/>	Leakage	<input type="checkbox"/>	<input type="checkbox"/>



## Tools to make your business successful

Members of MACS receive money saving discounts from the following strategic partners:

- Member exclusive A/C diagnostic mobile APP
- MACS Member discounts on **MOTOR e-tech**, **Identifix** and **Autodata** products
- Eight Annual Issues of **MACS ACTION™ Magazine**
- 12 monthly issues of MACS technical newsletter **MACS Service Reports**
- Access to MACS member only data and archives on the MACS website
- Access to **MACS Technical Helpline** to solve difficult repair problems

- Members receive discounts at **MACS Training Clinics** and annual **Training Event!**
  - Members receive discounts on all **AVI training products**, videos, DVDs and books!
  - **CINTAS**: offers exclusive MACS member discount pricing on uniforms, first aid supplies and more
  - **Group Health Insurance** - MACS members can custom design a health insurance plan and save money with Mass Marketing Health Insurance
  - **Business Insurance** – Need to insure your facilities? MACS members receive a discount from Evarts Tremaine Flicker Insurance
  - **Lenovo** computer discounts
  - **UPS Freight** – Savings on shipping and freight
- Discounts for **Hertz Car Rental**

For a full list of benefits visit [www.macsww.org](http://www.macsww.org)



## Application for Membership



NAME _____		COMPANY NAME _____	
ADDRESS _____			
CITY _____	STATE _____	ZIP _____	
COUNTRY _____			
PHONE _____	FAX _____		
E-MAIL ADDRESS _____	WEB SITE ADDRESS _____		

### MACS Worldwide

PO. Box 88  
 Lansdale, PA 19446  
 Phone: (215) 631-7020  
 Fax: (215) 631-7017  
 Email: [membership@macsw.org](mailto:membership@macsw.org)  
 Website: [www.macsww.org](http://www.macsww.org)

Complete and mail with membership payment to address above.

Is there anyone else you can recommend who might benefit from MACS membership?

NAME _____		COMPANY NAME _____	
ADDRESS _____			
CITY _____	STATE _____	ZIP _____	
COUNTRY _____			
PHONE _____	FAX _____		

Enroll me as a MACS member.

### APPLICANT SIGNATURE \_\_\_\_\_

Please send MACS Service Reports to me via email.

### Primary area of mobile air conditioning activity (check one):

- Service Shop (\$200 Annual Dues)
- Distributor (\$400 Annual Dues)
- Manufacturer / Supplier (\$700 Annual Dues)
- Educational     Associate     Individual (\$140 Annual Dues)

(Note: Educational membership is not open to shop owners, officers of an installer, distributors, or manufacturing companies.)

**Updated 01/01/2017**

- Enclosed is my check for \$ \_\_\_\_\_
- Please charge to (please check one)
- Mastercard     Visa     Discover     American Express

CARD # \_\_\_\_\_

SECURITY CODE \_\_\_\_\_ EXP. \_\_\_\_\_

SIGNATURE \_\_\_\_\_ DATE \_\_\_\_\_

Contributions or gifts to MACS Worldwide are not deductible as charitable contributions for Federal income tax purposes. Dues payments may be deductible by members as an ordinary and necessary business expense.



**Note:**

---

To learn more about the EPA stratospheric protection program or to order publications, call the EPA's Hotline at 1-800-296-1996 or check the EPA's website, located at:  
<https://www.epa.gov/mvac>

**Published by:**

---

**MOBILE AIR CONDITIONING SOCIETY (MACS) WORLDWIDE**

No part of this publication may be produced in any form, in an electronic retrieval system or otherwise, without the prior written permission of the publisher.

**National Office**

P.O. Box 88 • Lansdale, PA 19446  
Phone: 215-631-7020 • Fax: 215-631-7017  
E-mail: [info@macsw.org](mailto:info@macsw.org) • Website: <http://www.macsw.org>

**President:**

Elvis L. Hoffpauir

**MACS Technical Advisor:**

Ward Atkinson

**MACS Technical Editor:**

Steven G. Schaeber, Jr.

**Certification Training Manual:**

---

**Including: Refrigerant Recycling and Service Procedures for Mobile Air Conditioning Technicians  
and Best Service Practices**